

User Manual

Home Energy Storage System

Model: SunBeat series

SB5110/ SB7615/ SB1220

Version No.: V1

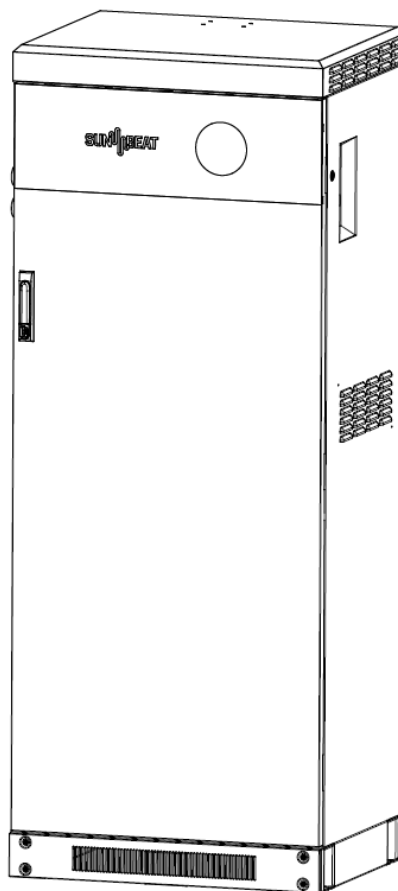

Catalogue

1	Safety Instructions.....	1
1.1	Safety Precautions.....	1
1.2	Symbolic Interpretation.....	1
2	Product Introduction	2
2.1	Product overview	2
2.2	Structural composition	2
3	Product Installation	6
3.1	Installation Precautions	6
3.2	Equipment List.....	6
3.3	Installation.....	7
3.3.1	Installation preparation.....	7
3.3.2	Installation guide.....	8
3.4	Cable connection.....	10
3.4.1	Install the waterproof connector	10
3.4.2	Grounding	10
3.4.3	AC input/output	11
3.4.4	PV connection	12
3.4.5	CT connection.....	14
4	Operating Instructions.....	15
4.1	Instructions.....	15
4.1.1	System power on.....	15
4.1.2	System shutdown	16
4.2	Monitor System Setup.....	17
4.2.1	Wifi/GPRS/4G/WLAN dongle connection.....	17
4.2.2	Setup the monitor system.....	18
4.2.3	Set homewifi password to dongle	19
4.3	Operation Guide.....	20
4.3.1	Self-usage Mode (Default)	20
4.3.2	Charge First Mode	21
	Application Scenarios.....	21
4.3.3	AC Charge Mode.....	22
4.4	Rapid shutdown.....	23
4.5	LCD Display.....	23
4.5.1	Viewing information and alarm/fault record.....	23
4.6.3	Operation Mode	32
4.7	Battery status display	33
4.8	Display status	35
5	Maintenance and Common Fault Handling	38
5.1	routine maintenance	38
5.2	Battery fault handling.....	38
5.3	Inverter fault handling.....	39
5.3.1	Regular Maintenance	39

5.3.2 LED Displays	40
5.3.3 Troubleshooting Based On LCD Displays	41
5.3.4 Fan replacement	44
6 Packaging, Shipping, Storage	46
Appendix A Technical Data Sheet.....	47













1 Safety Instructions

Before installing, using and maintaining the product, the user must read the manual carefully and operate in accordance with the safety precautions required by the contents of the manual. The safety precautions mentioned in this manual are only supplements to local safety regulations.

1.1 Safety Precautions

- The product must be installed and maintained by professionals in accordance with local standards and regulations, and strictly follow the installation steps in the manual.
- Before installation and maintenance, make sure that the power supply is disconnected to prevent electric shock or fire.
- During normal operation, it is strictly forbidden to directly touch the output, input and other terminals to avoid the danger of electric shock.
- During normal operation, do not open the casing of the machine directly, otherwise it will cause electric shock.
- Keep the device away from flammable and explosive materials and away from heat sources.
- It is forbidden to modify the equipment by yourself to avoid serious accidents.

1.2 Symbolic Interpretation

	Notice! Due to the hazard caused by non-compliance with the requirements, it may result in moderate or minor personal injury, as well as damage to the product!		This device must not be thrown away with other household waste and must be sent to the appropriate facility for recovery and recycling!
	Danger: high voltage danger, be careful of electric shock!		Recyclable!
	No smoking!		Do not tilt this side upside down!
	Stepping on is strictly prohibited!		Please read the manual carefully before use!
	The air outlet of the device is high temperature, be careful to touch it!		Protective grounding!
	After power off, wait 5 minutes to ensure the machine is fully discharged!		Grounding general identification!

2 Product Introduction

2.1 Product overview

The SunBeat series of home energy storage system products are composed of lithium batteries and bidirectional energy storage inverters (hereinafter referred to as PCS), providing renewable energy applications and uninterruptible power supply support services. The system can be used in scenarios where photovoltaics are self-generated and used and the surplus is connected to the Internet: during the day, the photovoltaic power generation first meets the electricity demand of the load, and the excess electricity is used to charge the battery or to the grid; when there is no photovoltaic at night, the load can choose to use the grid or battery to supply power.

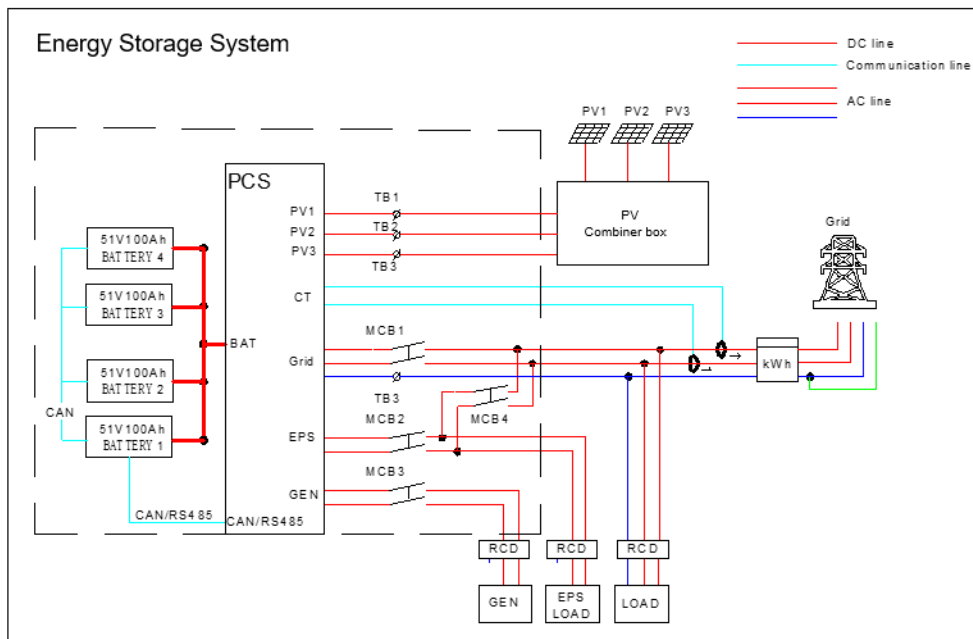

Figure 2-1 System Working Principle

2.2 Structural composition

The product adopts a modular design framework, and the battery box, energy storage inverter, and distribution box are installed in the form of components, which are convenient for replacement.

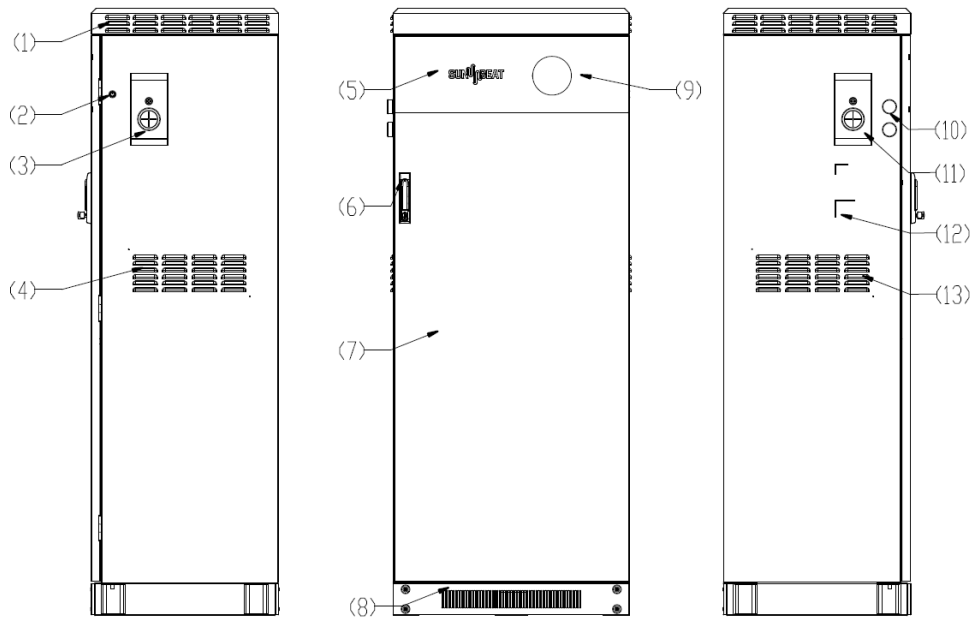

Figure 2-2 Product Appearance

- | | | | |
|---------------------------|-----------------|-----------------------------|-------------------------|
| (1) Cabinet top cover | (2) LAMP button | (3) Cable inlet and outlet | (4) Inverter air outlet |
| (5) LOGO | (6) Door lock | (7) Cabinet front door | (8) Cabinet base |
| (9) Display screen | (10) Antenna | (11) Cable inlet and outlet | (12) Label position |
| (13) Battery cooling port | | | |

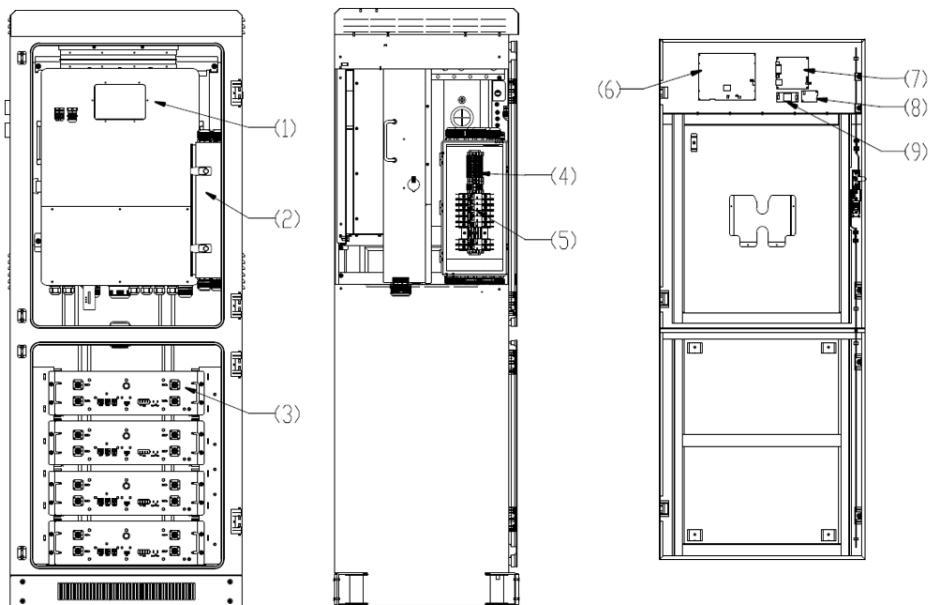

Figure 2-3 Internal composition of the product

- | | | |
|---------------------------|----------------------------|--------------------|
| (1) Inverter | (2) Power distribution box | (3) Battery module |
| (4) PV input terminal | (5) Circuit breaker switch | (6) Display |
| (7) Display control board | (8) Data acquisition unit | (9) Power module |

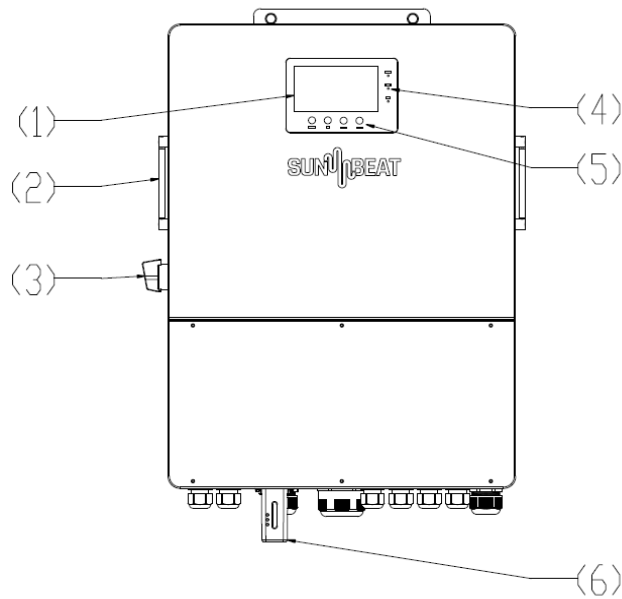

Figure 2-4 Appearance of the inverter

- | | | |
|---------------------------|----------------------|-----------------------------------|
| (1) LCD display DC Switch | (2) Handle | (3) DC Switch Inverter Indicators |
| (4) LCD display | (5) Function Buttons | (6) WiFi Interface |

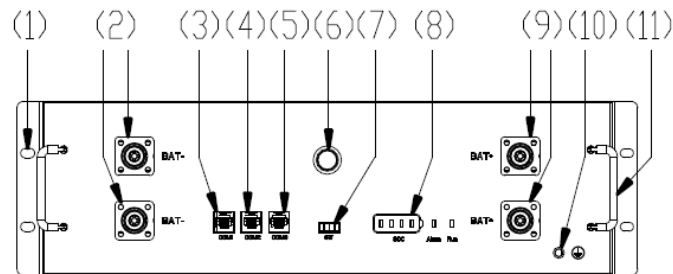

Figure 2-5 Appearance of the battery box

- | | | | |
|--------------------|-------------------------------|---------------------|-----------------|
| (1) Mounting holes | (2) Input and output negative | (3) RS485/CAN | (4) CAN/Address |
| (5) CAN/Address | (6) Button | (7) Dry node | |
| (8) Status Display | (9) Input and output positive | (10) Grounding hole | (11) handle |

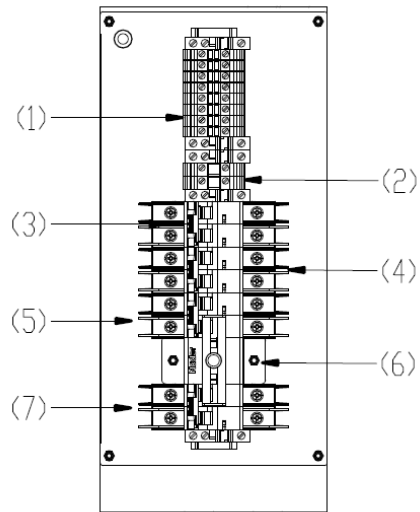

Figure 2-6 Internal view of the distribution box

- (1) PV terminal
- (4) Grid switch
- (7) Load switch

- (2) N wire terminal
- (5) Bypass switch

- (3) GEN switch
- (6) Interlock device

3 Product Installation

3.1 Installation Precautions

Before starting the installation, please follow the instructions below:



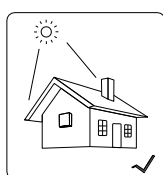



- Check whether the ambient temperature of the installation site is within the specified range of -20 °C to +55 °C (0 °C to 40 °C is recommended).
- The installation location is well ventilated, away from flammable and explosive materials, and it is forbidden to install and operate in a salt spray environment.
- The product should not be tilted or placed on its side.
- The product installation location should avoid sunlight, rain, snow, etc.



3.2 Equipment List

Before installation, please check whether the appearance of the machine is in good condition, and check whether the parts of the accessory bag are consistent with the list.

NO.	Picture	Material Name	Specification Model	QTY.
1		PV terminal block	E6012 Black	8
2		AC terminal block	EVN16-12 Milky Green	9
3		Terminals	RV5.5-6 Yellow	2
4		Cable tie	YJ-120 2.5*120mm Nylon White	30
5		Winding tube Φ 10	Roll Nylon Black	1

6		Expansion bolt	M12X80 Carbon Steel White Zinc Plated	4
7		Metal hose waterproof joint	M60*2	2
8		Energy storage battery system	SB5110/ SB7615/ SB1220 Energy storage battery system	1
9		General Certificate of Conformity	General Certificate of Conformity	1
10		Current transformer	/	2
11		Cable	/	1
12		User Manual	English	1

3.3 Installation

3.3.1 Installation preparation

The cabinet should be installed against the wall on the ground, and the height of the installation base should be greater than 200mm; keep both sides well ventilated, and the minimum clearance between the sides and the top should not be less than Figure 3-1.



The distance between the product and the doors and windows must be greater than 920mm.

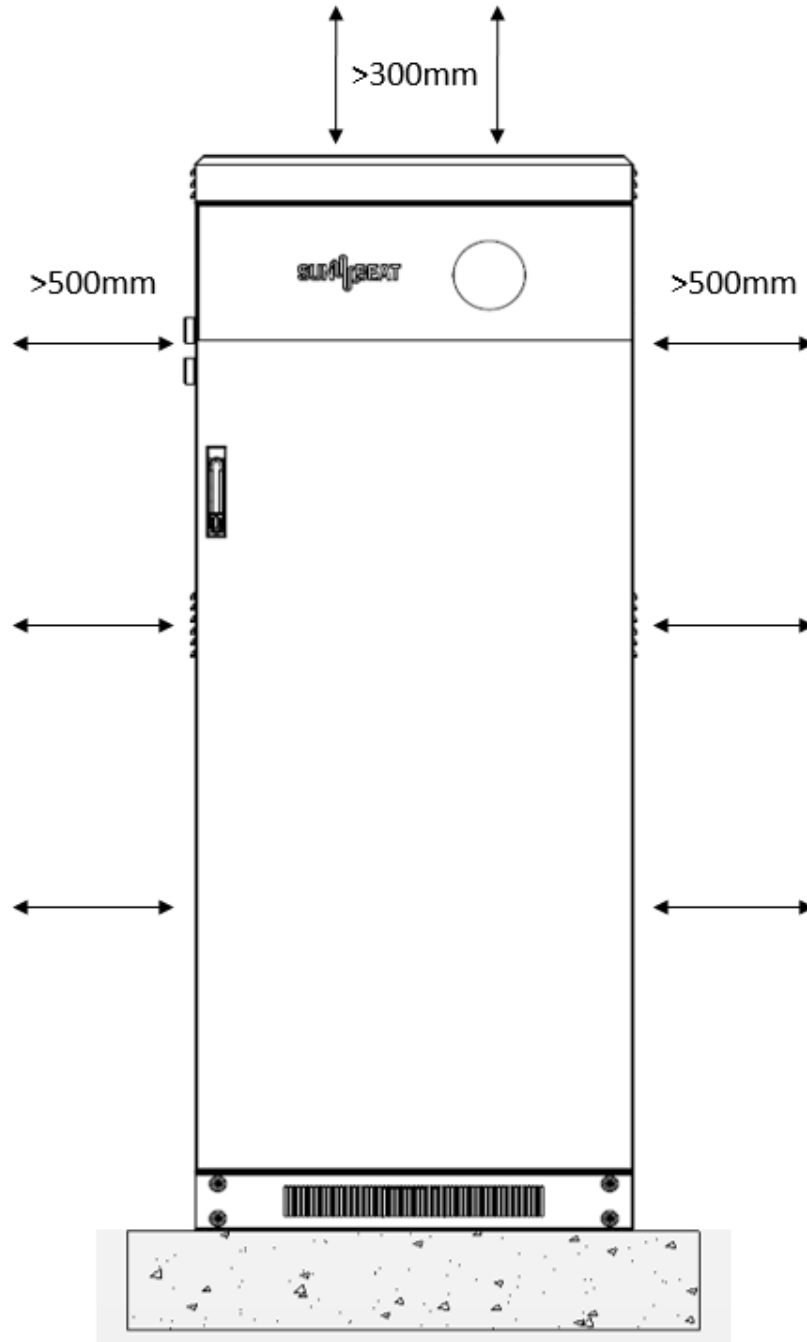

Figure 3-1 Installation schematic diagram

3.3.2 Installation guide

(1) The cabinet is installed on the floor, using expansion bolts to fix the cabinet on the base, and the base bears more than 1500KG.

The size of the opening of the base is shown in Figure 3-2:

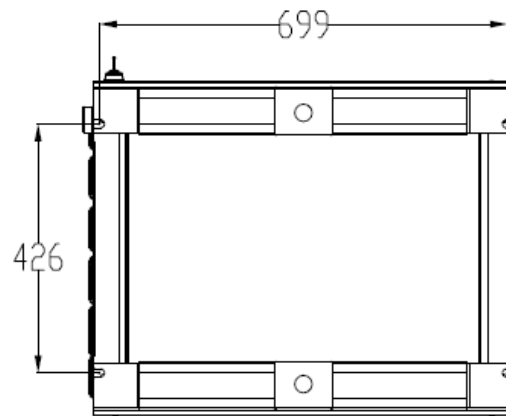

Figure 3-2 Dimensions of the opening of the cabinet base

(2) Use an impact drill to drill holes at the opening position according to the base hole size drawing. The diameter of the hole is 15mm and the depth is about 80mm, and the expansion bolt is knocked into the hole.

(3) Remove the front and rear covers of the base.

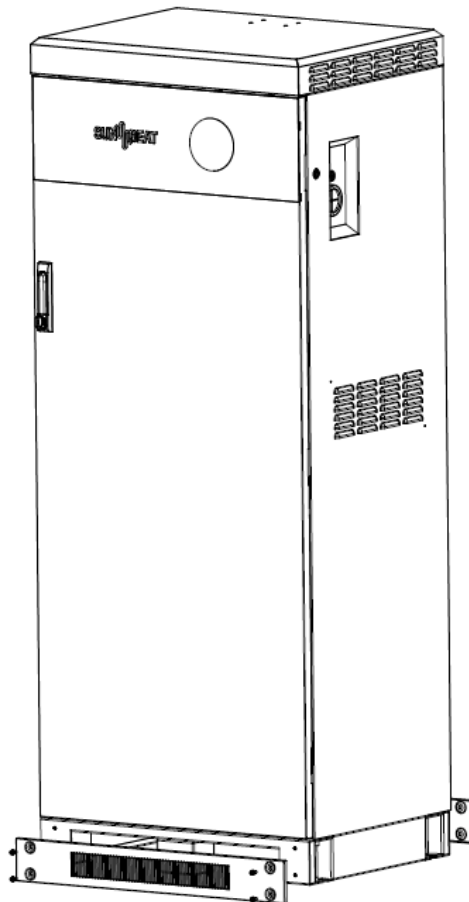

Figure 3-3 Removing the front and rear covers of the base

(4) Use a forklift to move the cabinet, align the holes on the cabinet with the base bolts, fix the nuts

of the expansion bolts, and replace the front and rear covers of the base to complete the fixed installation of the cabinet.

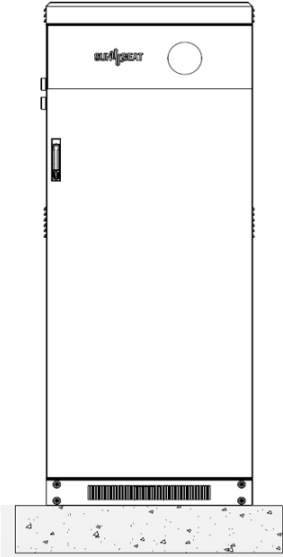
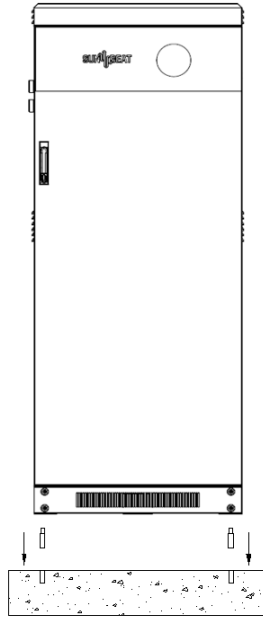

Figure 3-4 Cabinet installation and placement Figure 3-5 Cabinet installation completed

3.4 Cable connection

3.4.1 Install the waterproof connector

Before wiring, remove the protective coil on the cabinet and replace it with the waterproof connector in the spare part.

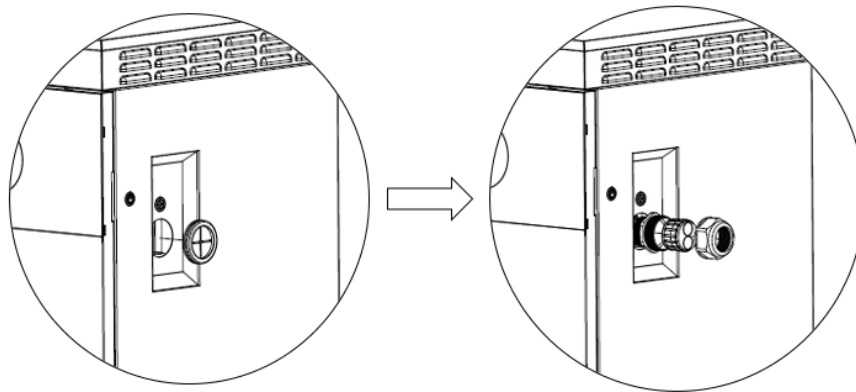

Figure 3-6 Installation of waterproof connector

3.4.2 Grounding

The ground cable should be connected to the common ground bar on the grid side to prevent electric shock. The recommended wire specifications for equipment grounding cables are as follows.

Model	Wire Size/Requirements	Cable(mm ²)
SB5110/SB7615/SB1220	8AWG Yellow-green two-color cable M6Ring terminal	8

Connect one end of the ground wire ring terminal to the grounding point on the top of the cabinet and the other end to the common grounding point.

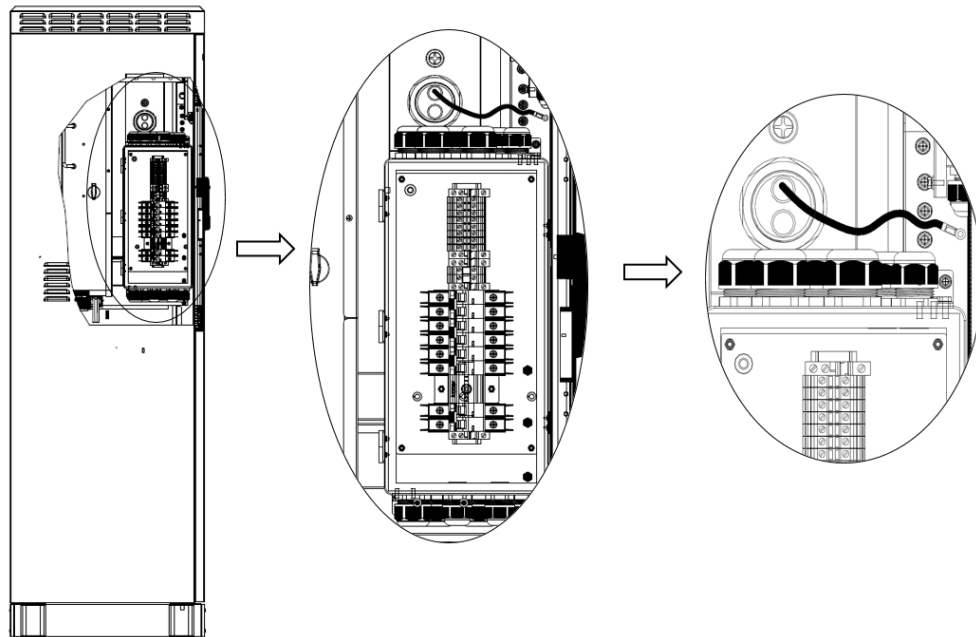

Figure 3-7 Cabinet ground cable connection

3.4.3 AC input/output

Please wire according to local electrical regulations, and connect the external N and PE wires of the system together, as shown in Figure 3-8.

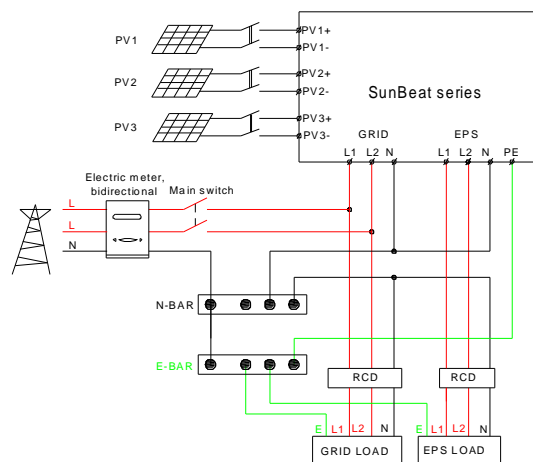

Figure 3-8 External wiring connection



- There are four circuit breakers with "GNE", "Grid", "Bypass" and "Load". Please do not connect cables by mistake.
- Before making AC input/output connections, make sure that the AC power is disconnected and the battery is turned off.

The recommended wire sizes for AC input/output are as follows.

Model	Wire Size	Cable(mm ²)
SB5110/SB7615/SB1220	6AWG	13

Follow the steps below to complete the AC input/output cable connection:

- (1) Strip the insulation layer of the cable with a length of 8 mm, cover the terminal, and then use a crimping tool to crimp the cable.
- (2) Loosen the circuit breaker wiring screws, insert the cables according to the polarity indicated on the cover, and tighten the screws to ensure that the cables are securely connected.

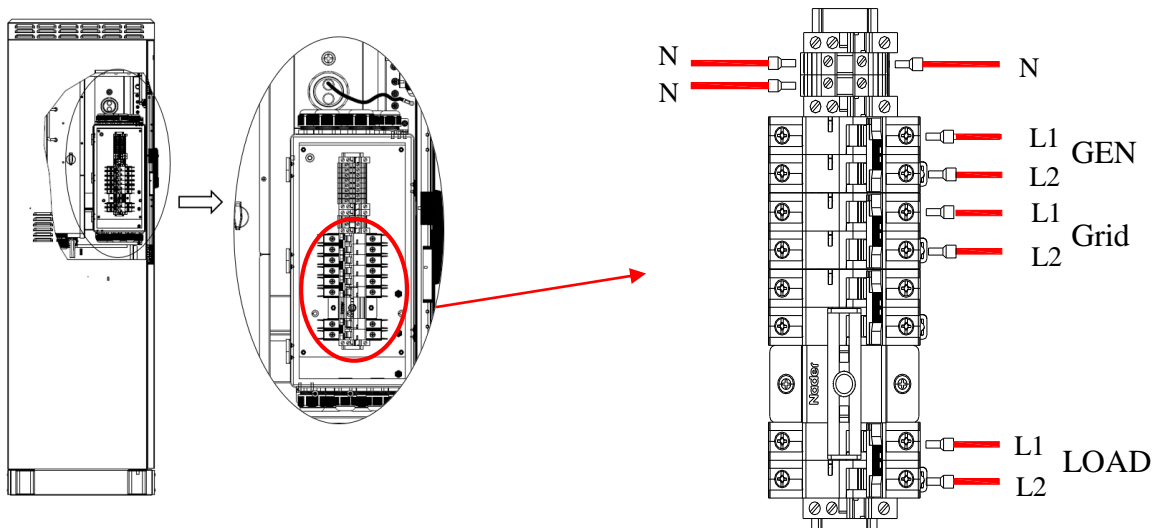

Figure 3-9 AC input/output connections

3.4.4 PV connection



- Before connecting to PV modules, please install a separately DC circuit breaker between inverter and PV modules.
- It is very important for system safety and efficient operation to use appropriate cable for PV module connection. To reduce risk of injury, please use the proper recommended cable size as below.

Model	Wire Size	Cable(mm ²)
SB5110/SB7615/SB1220	10AWG	5



- To avoid any malfunction, do not connect any PV modules with possible current leakage to the inverter. For example, grounded PV modules will cause current leakage to the inverter. When using PV modules, please be sure NO grounding.
- It is requested to use PV junction box with surge protection. Otherwise, it will cause damage on inverter when lightning occurs on PV modules.
- When selecting proper PV modules, please be sure to consider below parameters:

- 1) Open circuit Voltage (Voc) of PV modules not exceeds max. PV array open circuit voltage of inverter.
- 2) Open circuit Voltage (Voc) of PV modules should be higher than min. start voltage.

Model	SB5110/SB7615/SB1220
PV Input Voltage	360V(100V~600V)
PV Array MPPT Voltage Range	120Vdc-500Vdc
No. of MPP Trackers	3
No. of Strings per MPP Tracker	2/1/1

Follow the steps below to complete the PV cable connection:

- (1) Strip the insulation layer of the cable with a length of 8 mm, cover the terminal, and then use a crimping tool to crimp the cable.
- (2) Check that the polarity of the wiring from the PV module is correct. Then connect the positive (+) of the cable to the positive (+) of the PV terminal. Connect the negative (-) of the cable to the negative (-) of the PV terminal.

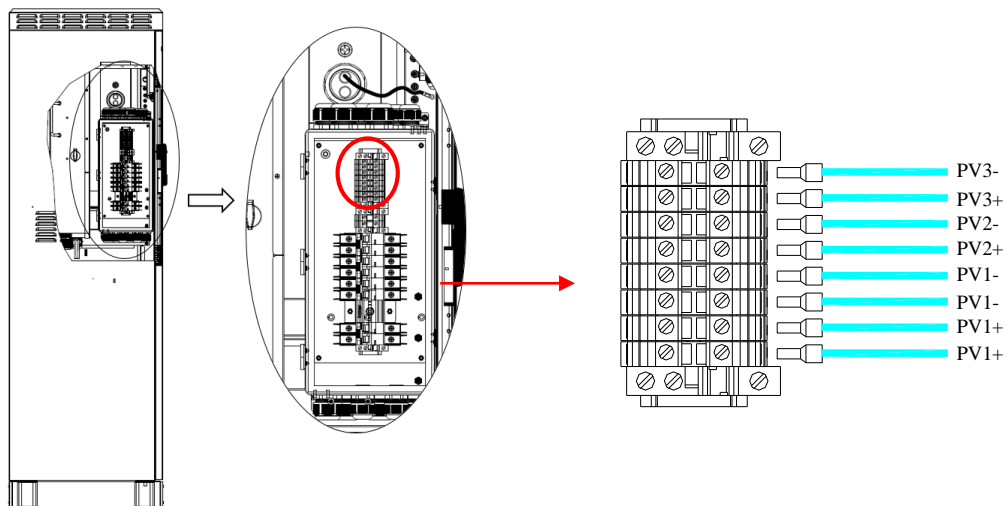

Figure 3-10 PV input connection

3.4.5 CT connection

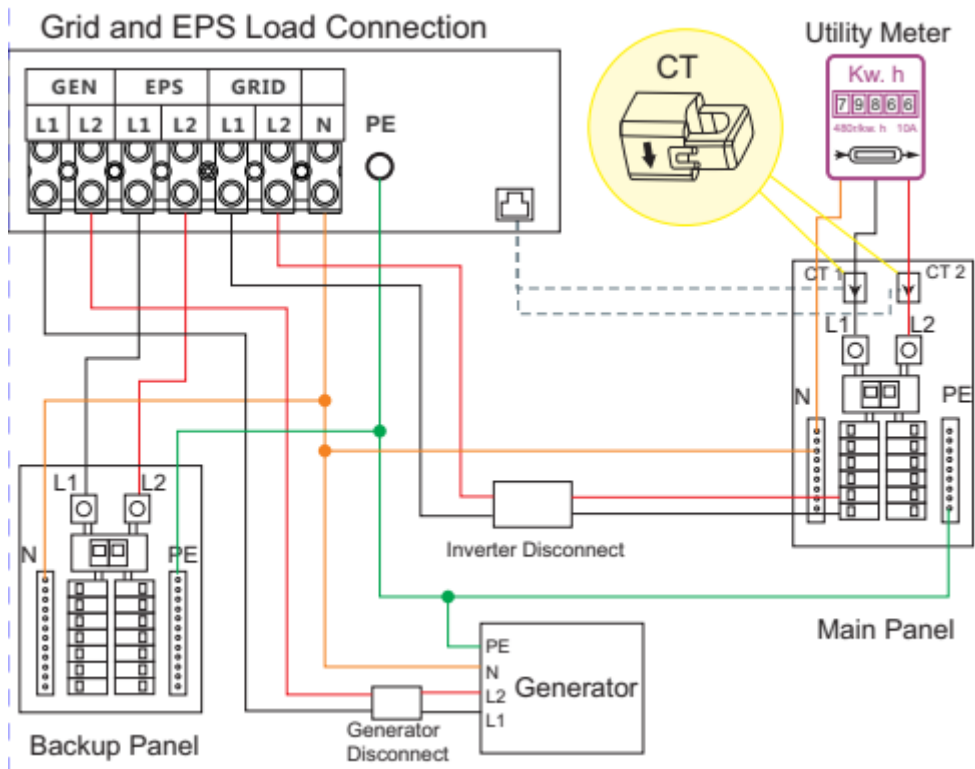

Figure 3-11 CT connection

4 Operating Instructions

4.1 Instructions

4.1.1 System power on

(1) Press the POWER button for 3S, the battery indicator lights up, and the battery is turned on.

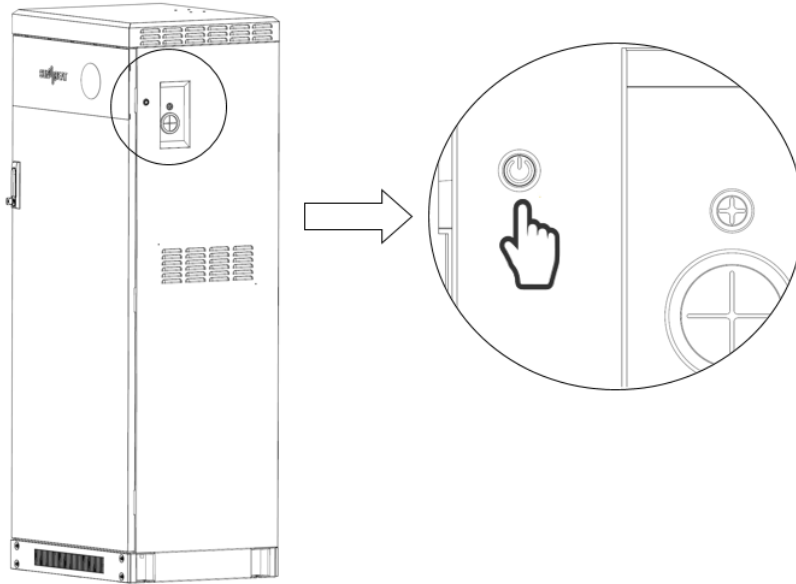

(2) Set the inverter DC switch to "ON".

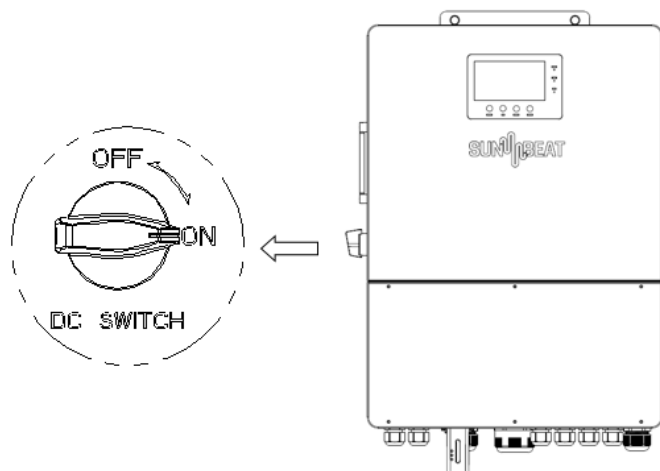

Be sure to close the photovoltaic switch before the photovoltaic power is available, otherwise the inverter may be damaged.

(3) When closing the "Grid" switch, push the operating handle of the Grid switch up.

(4) When closing the "Load" switch, push the interlocking device towards the Bypass switch and tighten it clockwise; then push the Load switch operating handle upwards.

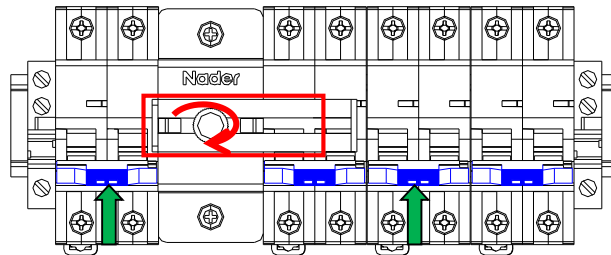

- The "Bypass" switch is only used during inverter maintenance and is not used by default.
- Before closing the "Bypass" switch, disconnect the "Load" switch
- Close the "Bypass" switch, and the load is powered by the mains.

When closing the "Bypass" switch, first loosen the interlock device in a counterclockwise direction, then push it in the direction of the Load switch, and tighten it in a clockwise direction; finally, push the Bypass switch operating handle upwards.

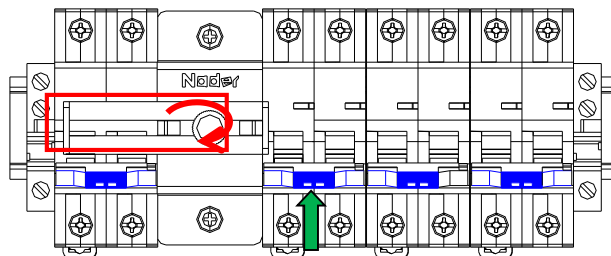

4.1.2 System shutdown

- (1) Open the "LOAD" switch.
- (2) Turn off the "GRID" switch.
- (3) Disconnect the "Bypass" switch.
- (4) Turn off the "GNE" switch.

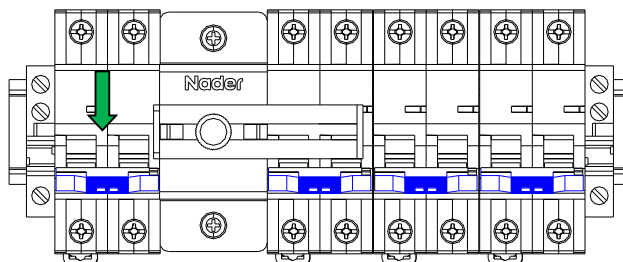

(5) Press the battery POWER button for 3S, the button will pop up, and the battery indicator will turn off.

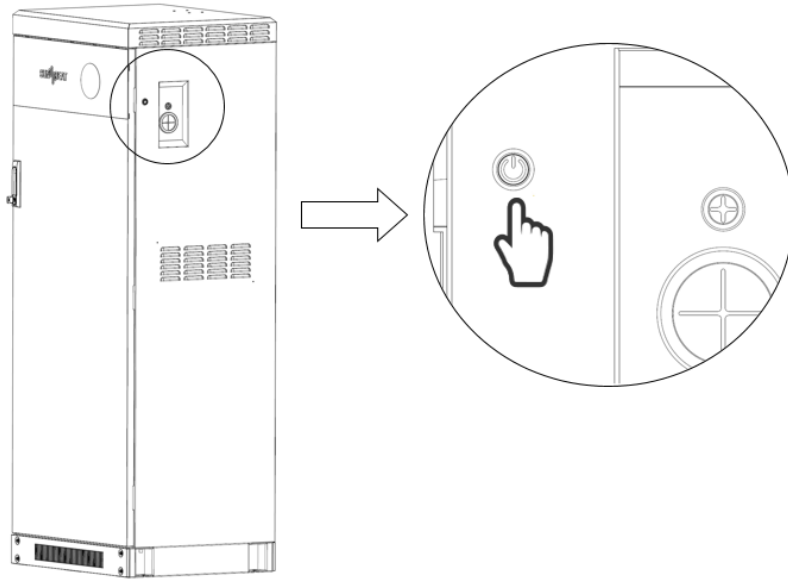

(6) Turn the inverter DC switch to "OFF" and press the ON/OFF switch to complete the system shutdown.

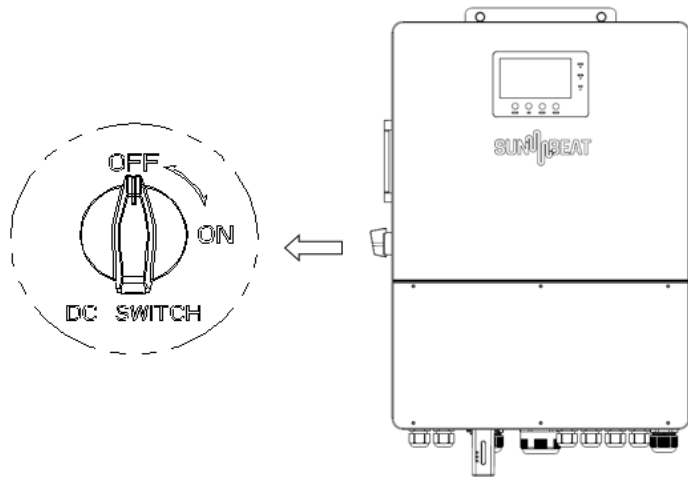

4.2 Monitor System Setup

4.2.1 Wifi/GPRS/4G/WLAN dongle connection

Users can use WiFi/ WLAN /4G /2G dongle to monitor their inverter, and view the monitoring data on computer or smart phone remotely.

To view data on smartphone, please download the APP from Google Play or Apple APP store, then login with their user account.

Available in google play or Apple APP store:



Andriod APP



IOS APP

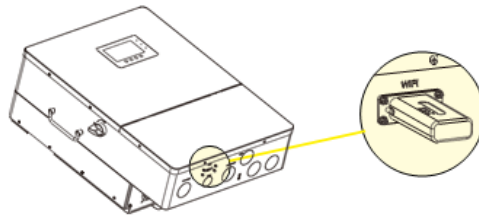

4.2.2 Setup the monitor system

- (1) Sign up an account on the mobile phone APP or Website

The "customer code" is a code we assigned to your distributor or installer. You can contact your supplier for their code.

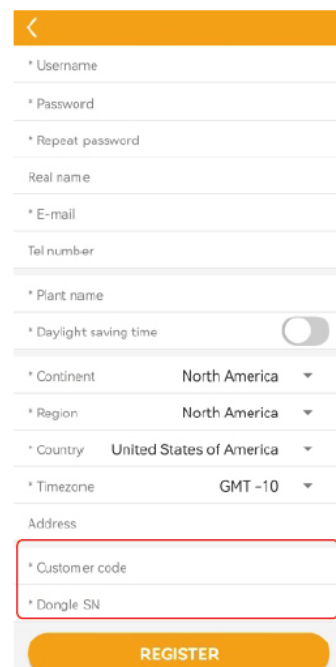
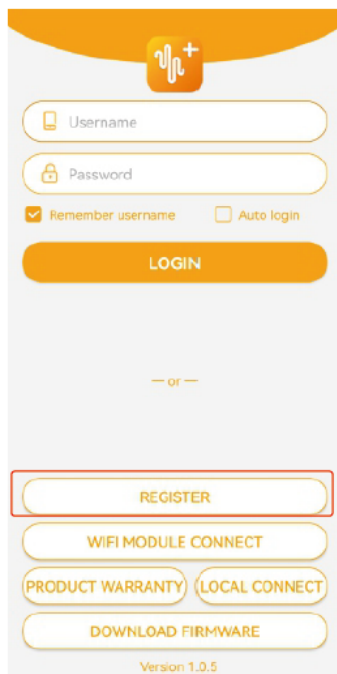

- (2) Create station and add dongle for the station



4.2.3 Set homewifi password to dongle

(1) Connect your mobile phone to the “BAxxxxxxx” wireless network where “BAxxxxxxx” is the serial number of the WiFi dongle.

(2) Click the "WiFi MODULE CONNECT" button on the APP.

(3) Select the home WiFi that the WiFi dongle is to be connected to, enter the WiFi's password. And then click "HomeWifi Connect". The WiFi dongle will restart and try to connect to our server automatically.

(4) Check the LEDs' status on the WiFi dongle. The middle light should be solid lit when the WiFi dongle connects to our server successfully.

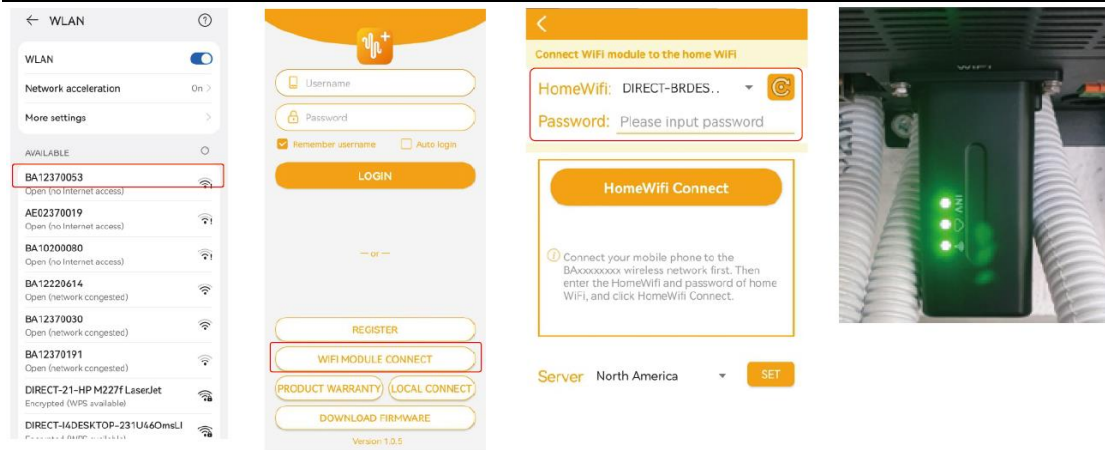

(5) Now you can disconnect your mobile phone from the “BAxxxxxxx” wireless network. Login on the APP with your account, you'll find the inverter information already appears. Now you'll be able to monitor and control the inverter remotely on any smart phone or computer that has Internet connection.

4.3 Operation Guide

Operation Mode

The inverter has different working mode to meet customers' various demands, the working modes are as below:

4.3.1 Self-usage Mode (Default)

In this mode, the priority order of load supply source is Solar>Battery>Grid. The priority order of solar power usage is Load>Battery>Grid.

Application Scenarios

Self consumption mode will increase self consumption rate of solar power and reduce the energy bill significantly

Related Settings

Effective when Charge Priority , AC Charge, and Forced discharge are disabled

Example

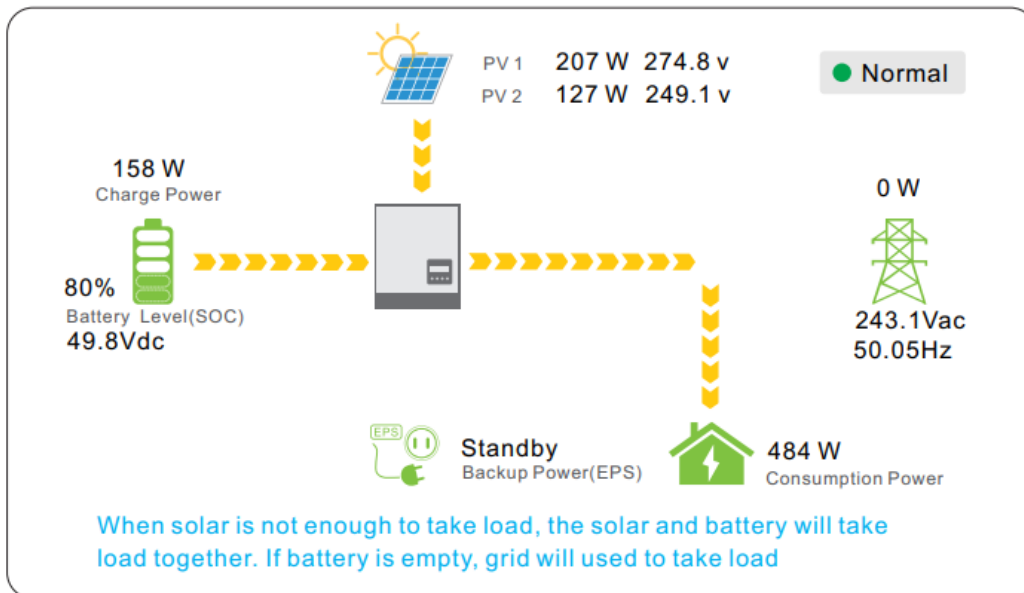
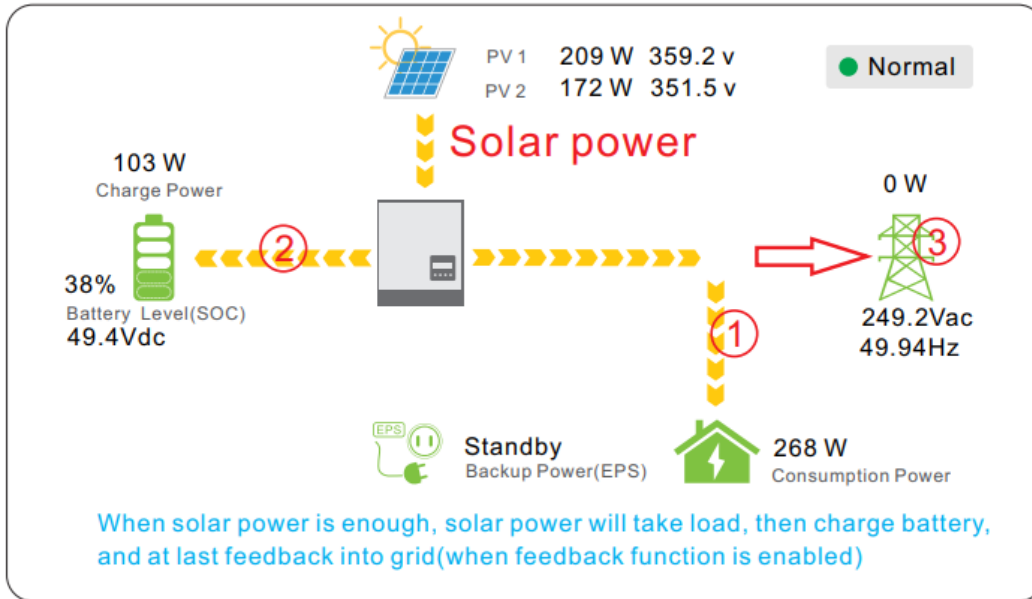

4.3.2 Charge First Mode

The priority order of solar power usage will be Battery >Load >Grid. During Charge Priority time period, load is first supplied with grid power. If there is excess solar power after battery charging, the excess solar power will take load together with grid power.

Application Scenarios

When users want to use solar power to charge battery, grid power to supply load.

Related Settings

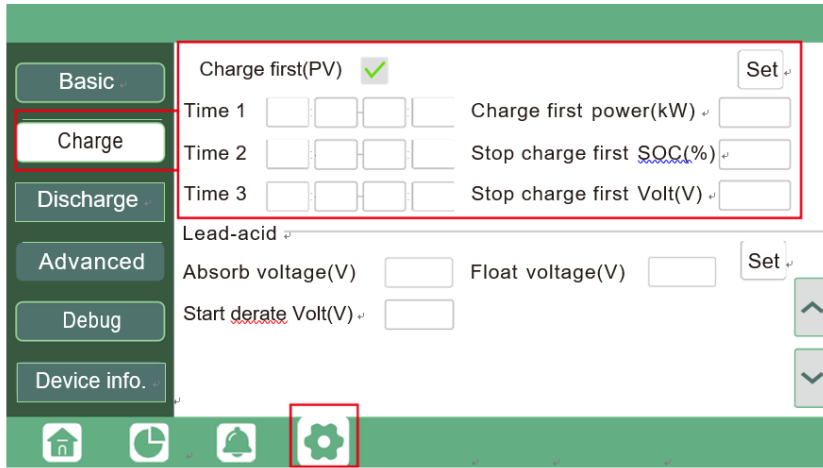

Example

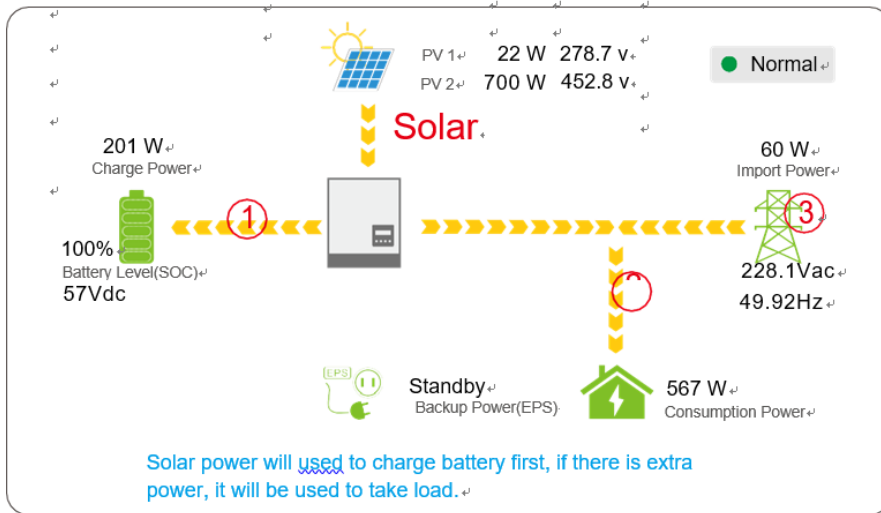

4.3.3 AC Charge Mode

Users can charge battery with grid power when electricity price is cheap, and discharge battery power to supply load or export to the grid when electricity price is high.

Application Scenarios

When users have a Time of Use(TOU) rate plan.

Related Settings

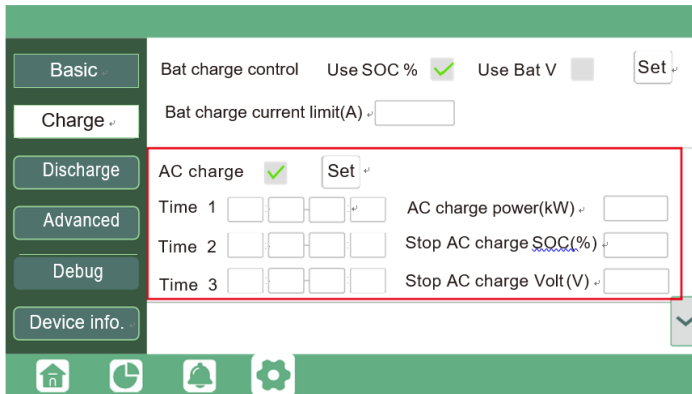

4.4 Rapid shutdown

The inverter includes a rapid shutdown system that complies with 2017 and 2020 NEC 690.12 requirements. A rapid shut switch should be connected to the terminals x and x on the inverter, and mounted on a readily accessible place out of the property.

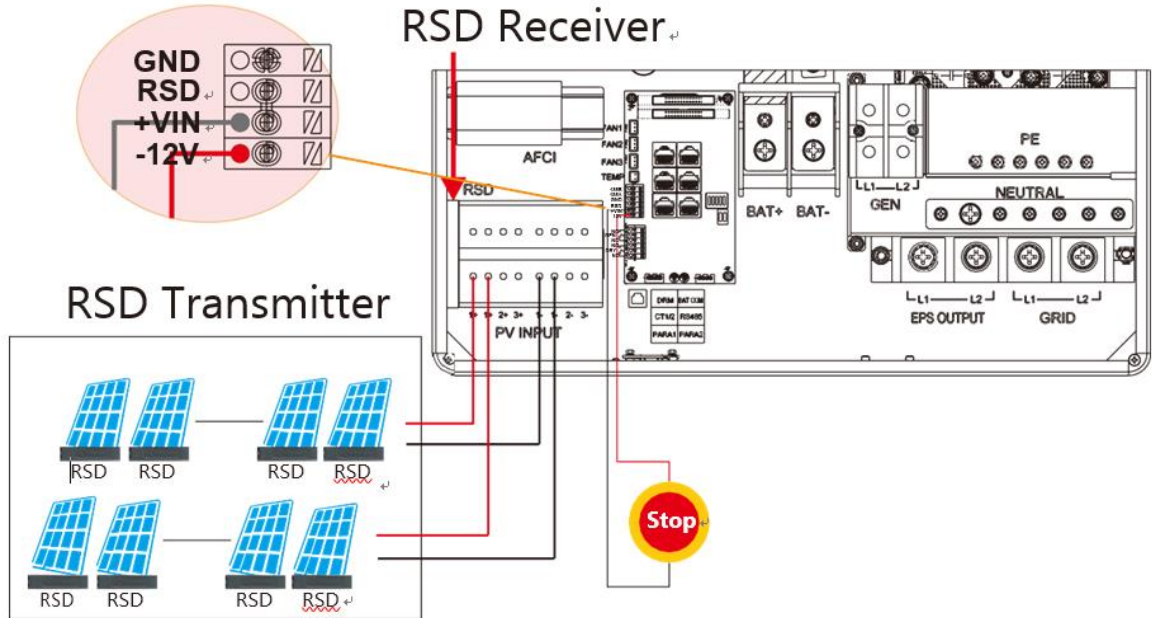

The Rapid shut down switch should be connected to VIN and 12V.

In case of emergency, press the rapid shutdown switch, the PV conductors voltage will be reduced to less than 30V within 30 seconds.

4.5 LCD Display

Users can view inverter running status, real time power, daily and accumulated energy information conveniently on inverter LCD. In addition to the above information, users can also check alarm and fault record on the display for troubleshooting.

4.5.1 Viewing information and alarm/fault record

Home Page

Touch the screen to light it up if it's in sleep mode. The Home page will appear on the display. Users will see a system overview diagram along with the real time information of each component, such as battery SOC, battery charging/discharging power, grid import/ export power, load power, etc. On the right part of the screen, users can check daily and accumulated solar energy, battery charged/discharged energy, grid imported/exported energy, as well as load consumption.

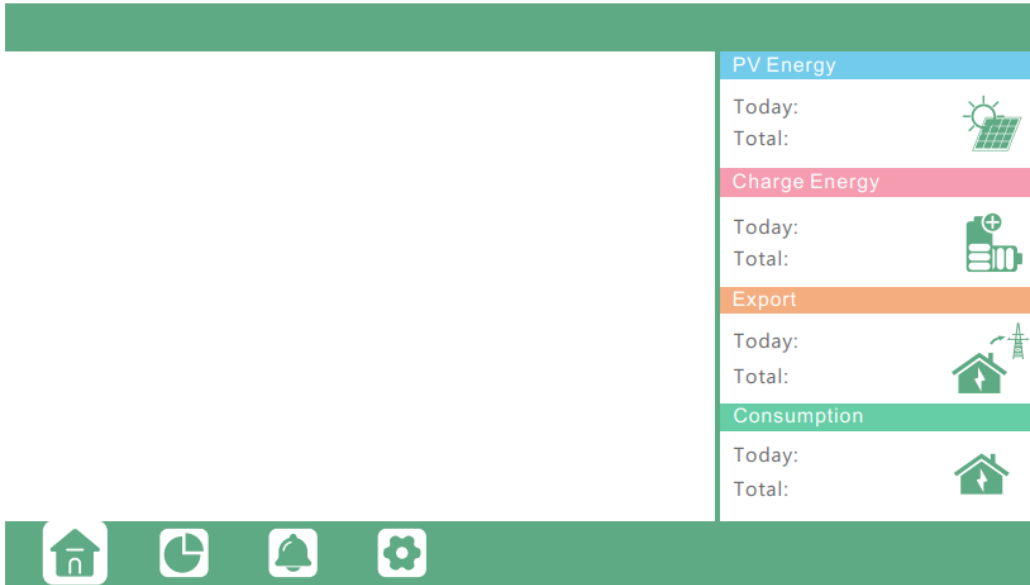

Detailed System Information

Click on the pie icon at the bottom of the screen, you'll be able to view the detailed real time solar information, battery information, grid information and EPS output information.

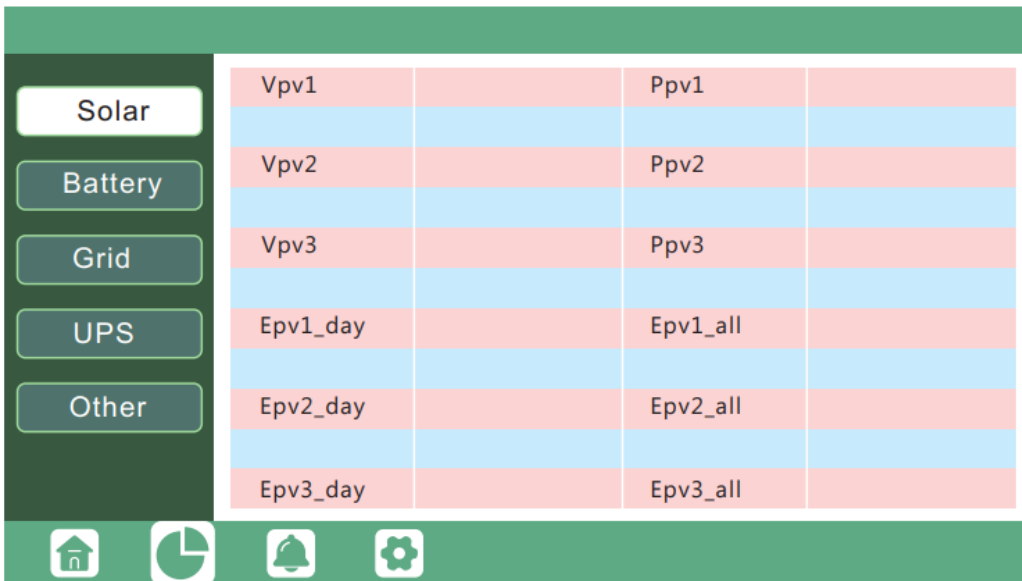

Solar	Vbat	Ibat
Battery	Pchg	Pdischg
Grid	Vbat_Inv	BatState
UPS	SOC/SOH	CycleCnt
Other	Vchgrf	VcutVolt
	I maxchg	I maxdischg
	Vcellmax	Vcellmin
	Tcellmax	Tcellmin
	BMSEvent1	BMSEvent2
	Echg_day	Edischg_day
	Echg_all	Edischg_all

Solar	Vgrid	Fgrid
Battery	VgridL1N	VgridL2N
Grid	Vgen	Fgen
UPS	Pimport	Pexport
Other	Pinv	Prec
	Pload	
	Eimport_day	Eexport_day
	Eexport_all	Eexport_all
	Einv_day	Erec_day
	Einv_all	Erec_all
	Eload_day	Eload_all

Solar	Vups	Fups
Battery	VupsL1N	VupsL2N
Grid	Pups	Sups
UPS	PupsL1N	SupsL1N
Other	PupsL2N	SupsL2N
	Eups_day	Eups_all
	EupsL1N_day	EupsL1N_all
	EupsL2N_day	EupsL2N_all

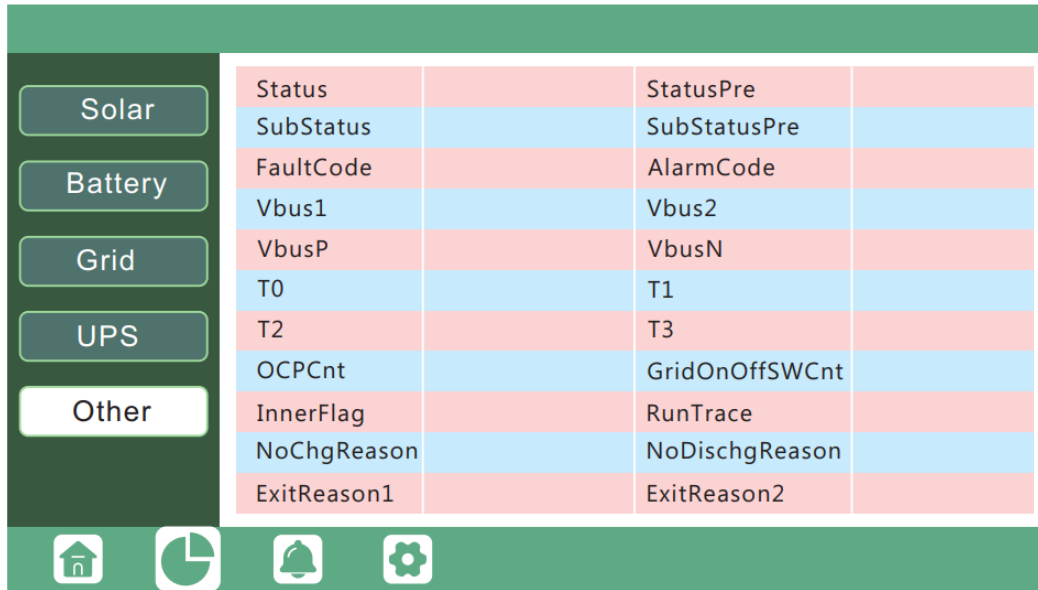

Fault/Alarm Information

Touching the bell icon at the bottom of the screen, you'll see all current and historical fault & warning information on this page.

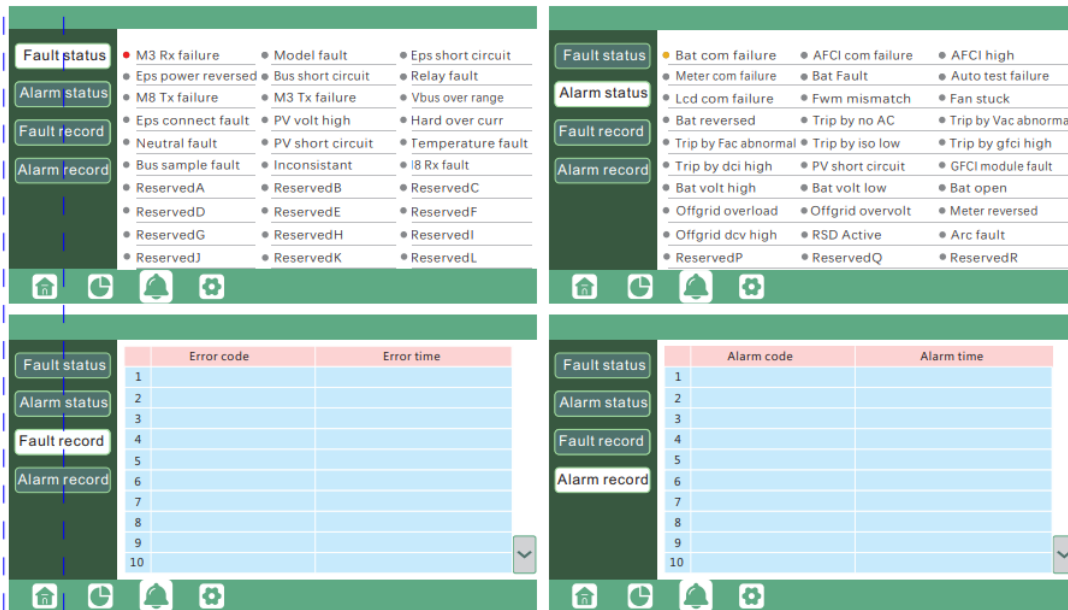

4.5.2 Setting Parameters

Clicking on the gear icon at the bottom of the screen, you'll get into the parameter setting page of the inverter.

a. Basic settings

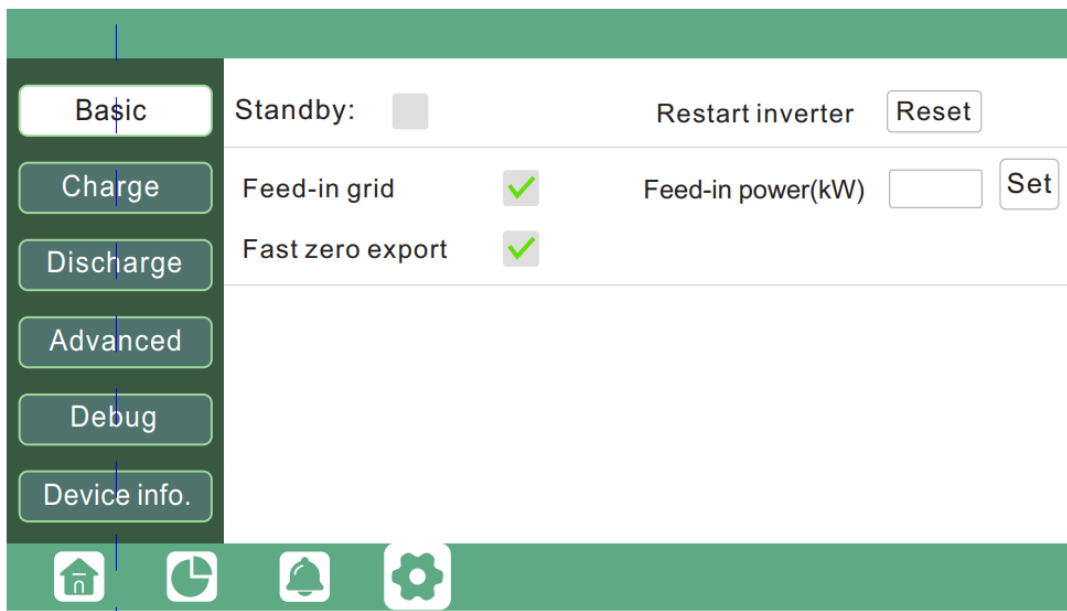

Standby: Is for users to set the inverter in normal status or in standby status. In Standby status, the inverter will stop any charging or discharging operation, as well as solar-feed-in.

Restart inverter: Restart the system, please note the power may be interrupted when restart

Feed-in Grid: Is for users to set zero export function. If exporting solar power is not allowed, users need to disable “Feed-in Grid” option. If users' utility meter will be tripped with even a little solar export, “Fast zero export” can be enabled thus the export detection and adjustment will take place every 20mS, which will effectively avoid any solar power being exported. If export is allowed, users can enable “Feed-in Grid” and set a maximum allowable export limit in “Feed-in Power(%)”(in % term).

b. Charge setting

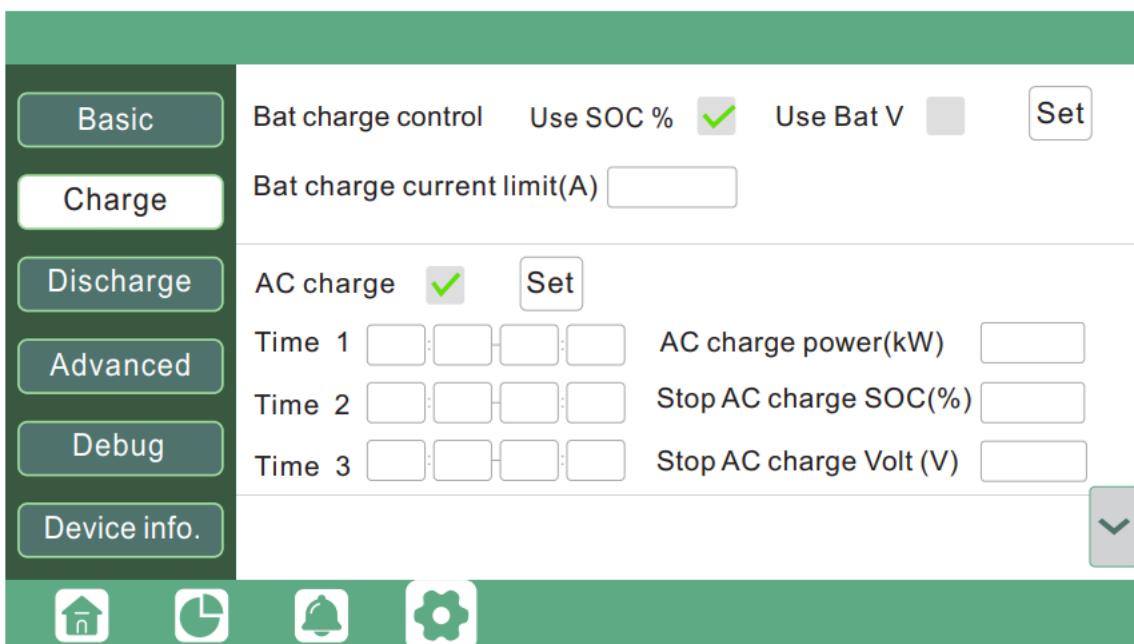

Bat charge control: Users can decide to use SOC or BatV to control charge and discharge logic depends on battery type.

Bat charge current limit(A): Users can set Max charge current.

AC Charge: Setting for utility charge. If users want to use gridpower to charge battery, then they can enable “AC Charge”,

set time periods when AC charging can happen, AC Chargepower(kW) to limit utility charging power, and “Stop AC ChargeSOC(%)” as the target SOC for utility charging. “Stop AC Volt(V)”as the target battery voltage for utility charging.

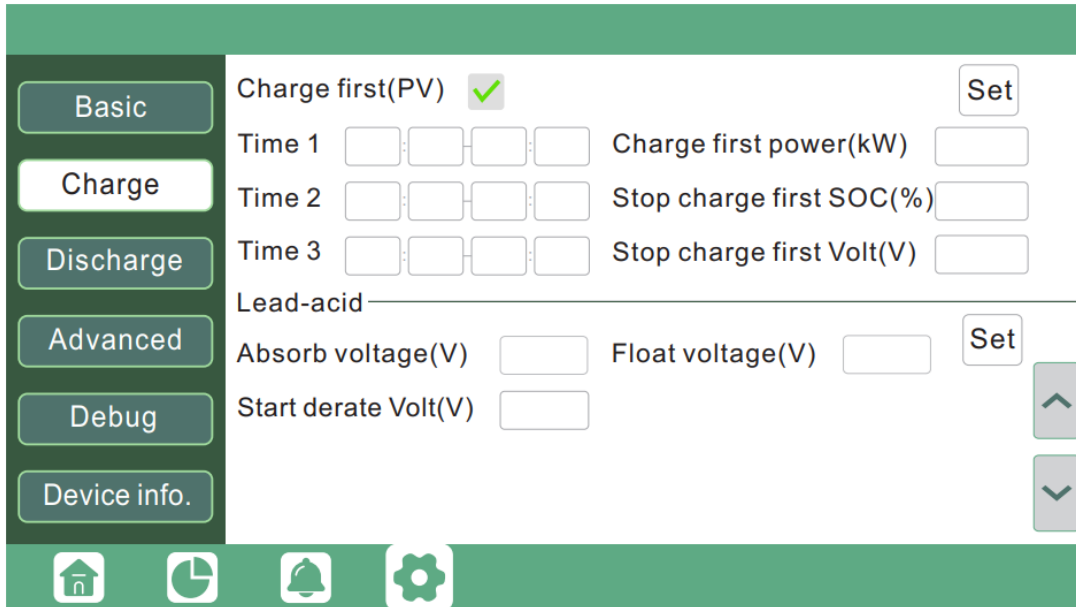

Charge first: Setting for PV charge. When uses enable Chargefirst, PV will charge the battery as priority, set time periods whenPV charge can happen, Charge first power(kW) to limit PV chargepower, and “Charge first SOC(%)” as the target SOC for PV chargefirst. “Charge first Volt(V)” as the target battery voltage for PVCharge first.

Lead acid: When uses connect Lead-acid battery, need setparameter in these programs, follow the battery manufacturer'srecommendation.

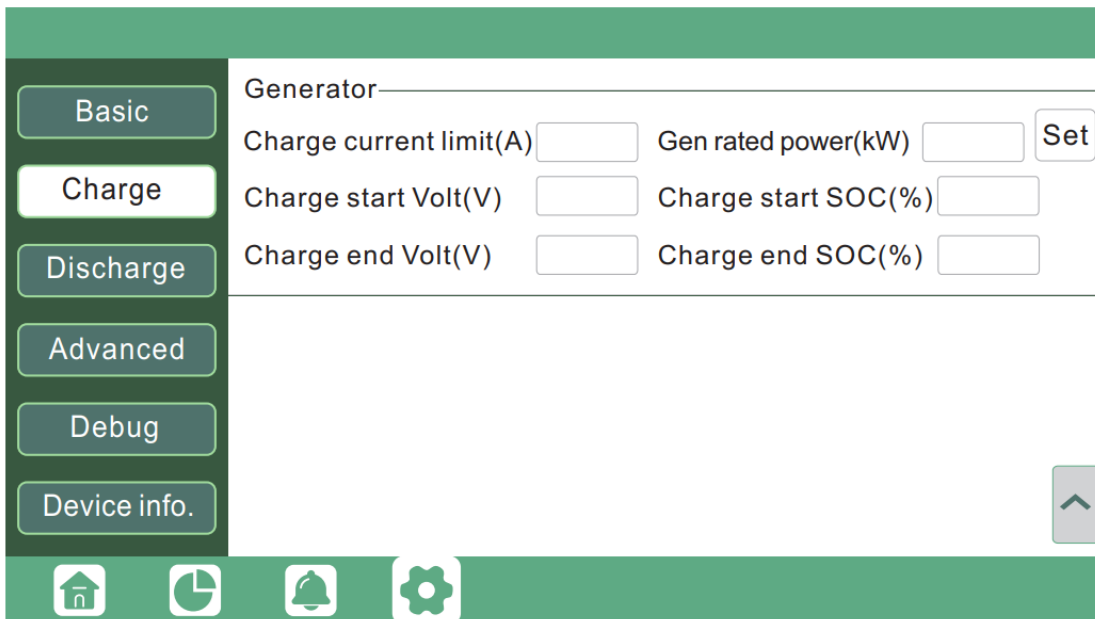

Generator

Bat charge current limit(A): Set the Max. battery chargecurrent from Generator. Generator will start charging accordingto the Charge start Volt/SOC,and stop charging when thebattery voltage or SOC get the Charge end Volt/SOC value.

Gen rated power:Inverter has the peak-shaving function,when you need you can enable it and setup the Gen peak-shaving power(W)

c. Discharge setting

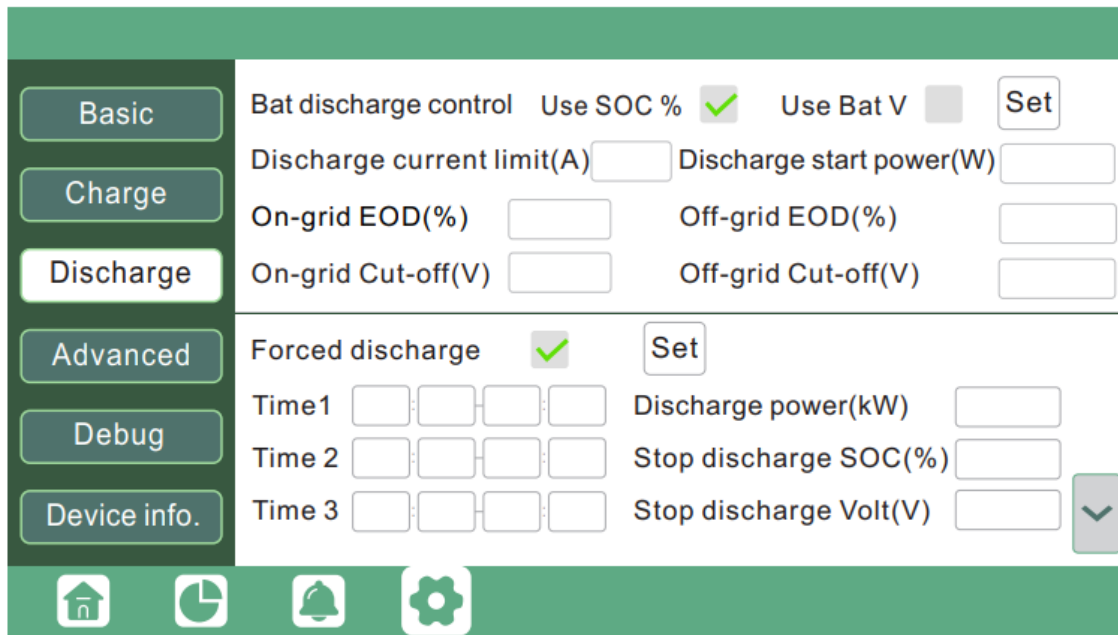

Bat discharge control

You can choose “Use SOC %” or Use Bat V” to control the battery discharge state

Discharge current limit(A): The Max. discharge current from battery

Discharge start power(W): The Min. value can be set to 50.When the inverter detect the import power is higher than this value, battery start discharging, otherwise battery will keep standby

On-grid EOD(%) and Off-grid EOD(%) /On-grid Cut-off(V)and Off-grid Cut off(V): End of discharge SOC/Cut off voltagein on-grid and off-grid condition respectively.

Forced discharge: Settings for battery force discharge withincertain time period. In the preset time period, the inverter willdischarge battery at the power set by “discharge power”, untilbattery SOC or voltage reaches “Stop discharge ”value.

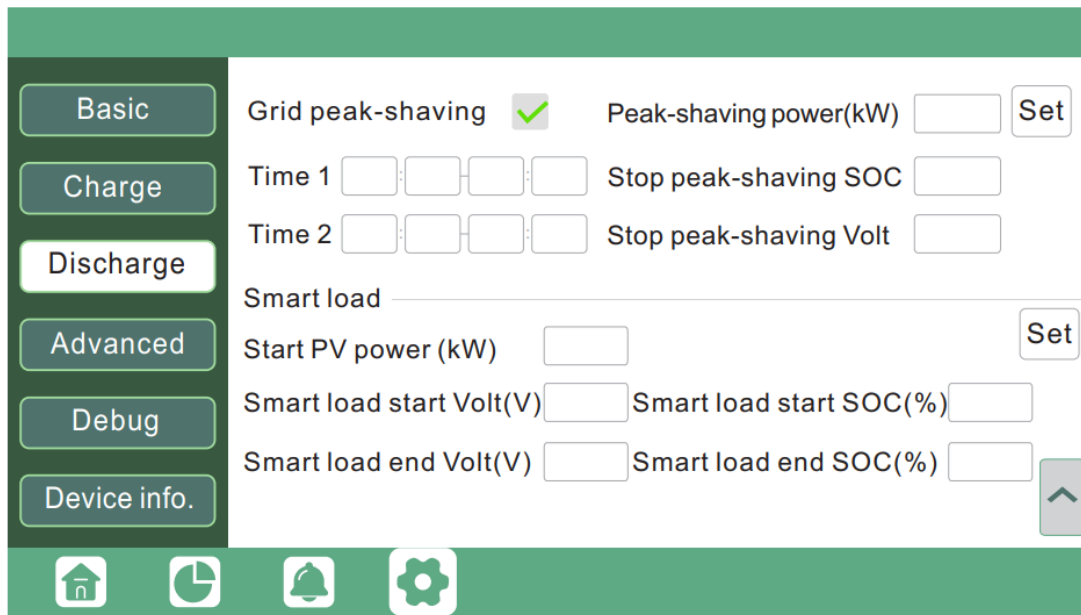

Note: If you enable the Smart load function, it's forbidden to connect the generator at the same time, otherwise the device will be damaged!

Grid peak-shaving & Grid peak-shaving power(kW):

Is used to set the maximum power that the inverter will draw from its grid power.

Advanced setting: Advanced setting is mainly by installer after installation.

SmartLoad: This function is to make the Gen input connection point as a load connection point, if you enable it, inverter will supply power to this load when the battery SOC and PV power is above a user setup value. e.g. Smart load start SOC=90%, Smart load end SOC=85%, Start PV power=300W, it means: When the PV power exceeds 300W, and the battery system SOC gets to 90%, the Smart Load Port will switch on automatically to supply the load which is connected on this side. When the battery reaches SOC<85% or PV power<300w, the Smart Load Port switch off automatically.

d. Advanced setting

Advanced setting is mainly by installer after installation.

Grid type: You can choose by yourself,240/120V,220/108V

Battery type:No battery,lead-acidorlithium-ion.

If lead-acid battery is selected, please input correct battery capacity

If lithium-ion battery is selected,please choose the battery brand in the Lithium brand drop down list.

The supported CT ratio is 1000:1 and 3000:1. default CT ratio is 3000:1. If 3rd party CT is to be used, please ensure its CT ratio is either 1000:1 or 3000:1, and set it accordingly. the battery brand in the Lithium brand drop down list.

Meter type:Please select it according to the meter that's to be installed.

Offgrid output: Is for users to set if the inverter provides backup power or not when the grid is lost.If users want load to be seamlessly transferred to inverter backup power,“Seamless switch”must be enabled.If customers don't have battery installed yet, but still wish to have inverter backup power

with only solar panels connected, “PV Grid Off” can be enabled to use solar power to supply load when grid fails or load-shedding happens. Micro-grid:only needs to be set when generator is connected at the inverters grid port.With this option enabled, the inverter will use AC power to charge battery and won't export any power through grid port if AC power is present at inverter grid port.

Chargelast:When users want to use solar power in the order of loads—grid export—battery charging.

CT direction reversed: When the CT is installed on the wrong direction,installer can modify it by selectingit, no need reconnect.er in the order of loads--grid export --batterycharging.

4.6 Start-up and shut down the inverter

4.6.1 Start up the inverter

Step1. Turn on the battery system firstly, then turn on the DC breaker between battery and inverter.

Step2. Make sure the PV voltage of the strings are higher than 120V ,and check if the inverter works in PV charge or PV charge back-up mode.

Step3. Make sure step1and 2 above work properly before turning on the grid power or generator breaker, and check if the inverter can go to bypass mode and on-grid mode normally.

4.6.2 Shut down the inverter

Danger: Do not disconnect the battery , PV and AC input power under load.

If there is emergency issue , and you have to shut down the inverter ,please follow the steps as below.

Step1. Turn off the Grid breaker of the inverter.

Step2. Switch off the load breaker.

Step3. Turn off PV breaker and then battery breaker, waiting for the LCD to go off.

4.6.3 Operation Mode

The inverter has different working mode to meet customers' various demands, the working modes are as below:

Self-usage Mode (Default)

In this mode, the priority order of load supply source is Solar>Battery>Grid. The priority order of solar power usage is Load>Battery>Grid.

Application Scenarios

Self consumption mode will increase self consumption rate of solar power and reduce the energy bill significantly

Related Settings

Effective when Charge Priority , AC Charge, and Forced discharge are disabled

Examp

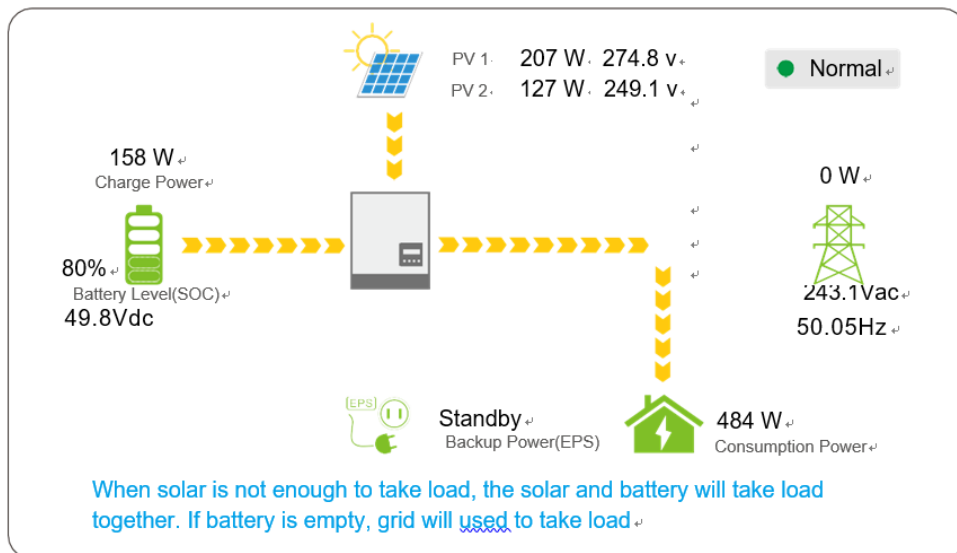
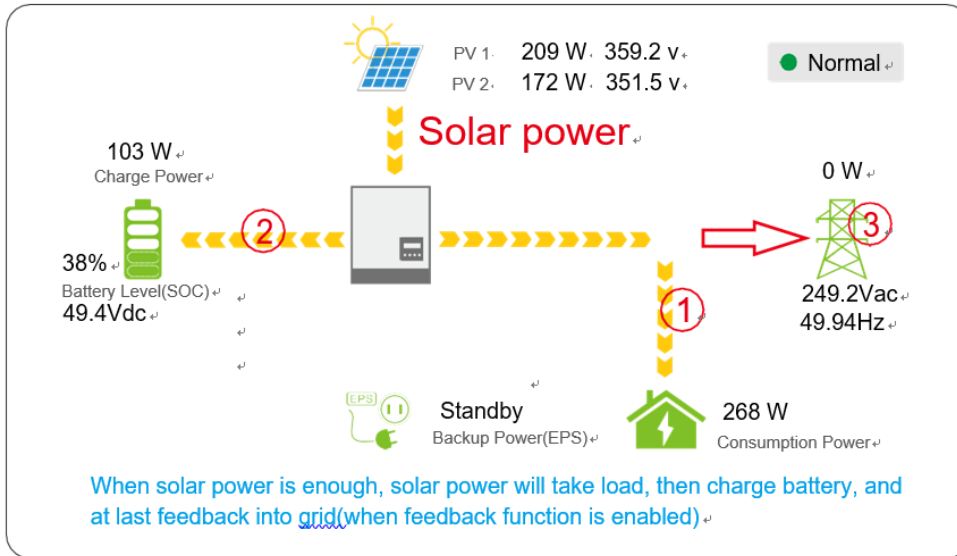

4.7 Battery status display

Through the LED status indicator on the battery pack, you can check the SOC and running status of the battery pack. The indicators are LED1-LED6 in order from left to right. LED5 and LED6 of the 1# battery pack display the fault summary status of the battery cabinet. , that is, when any battery pack of the system fails, the LED of the 1# battery pack will display the current fault.

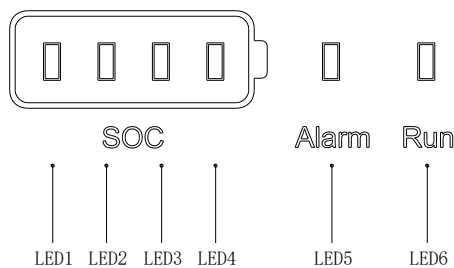

Figure 4-2 Intention of the battery display window



The battery has 6 LED indicators, including alarm, running, and power display (4). The function description is shown in the following table:

Battery status		Battery LED (low to high)				ALM	RUN	illustrate
Shutdown								All off
Charge	0%-25% capacity	★	★	★	★		●	The power LED light (1^4) from low to high is the status of the running water light
	26%-50% capacity	●	★	★	★		●	The power LED light (2^4) is running water light status from low to high
	51%-75% capacity	●	●	★	★		●	The power LED light (3^4) from low to high is the status of the running water light
	76%-99% capacity	●	●	●	★		●	Battery LED 4 blinks
	100% capacity	●	●	●	●		●	Charge cut off
Discharge	1%--25% capacity	●					●	
	26%--50% capacity	●	●				●	
	51%--75% capacity	●	●	●			●	
	76%--100% capacity	●	●	●	●		●	
	3% capacity	★					●	
Protection	Undervoltage protection	●				●	●	Cell undervoltage
	Overvoltage protection				●	●	●	Monomer overpressure
	Discharge overcurrent protection			●		●	●	
	Charging low temperature protection	●	●			●	●	
	Charging high temperature protection	●		●		●	●	
	Discharge low temperature protection	●			●	●	●	

	Discharge high temperature protection		●	●		●	●	
	MOS tube high temperature protection		●		●	●	●	
	Discharge short circuit protection	●	●		●	●	●	
Fault	Charging MOS failure failure	●				●		
	Discharge MOS failure fault		●			●		
	Voltage front-end sampling failure			●		●		
	Voltage front end disconnection fault				●	●		
	Temperature front-end sampling failure	●	●			●		
	Serious cell imbalance failure		●	●		●		
	Parameter configuration error fault		●		●	●		
	Parallel address conflict			●	●	●		
	Short circuit protection lockout	●		●		●		
	Front-end chip initialization failed	●			●	●		
	Front-end chip failure	●	●	●		●		
	Pre-discharge failed	●		●	●	●		
	Note: ● means always on, ★ means flashing, the flashing frequency of the indicator light is 1Hz.							

4.8 Display status

After the equipment runs normally, the display screen will display the corresponding status, and the corresponding display status is explained in the following table.

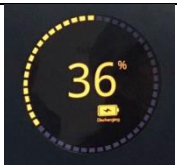
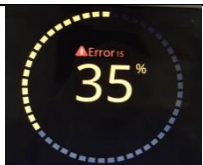
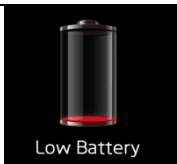
No.	State diagram	Status Description
1		When powered on, the software version number will be displayed, including the main control software version and the display software version.
2		While the device is charging, the "Charging" icon lights up.
3		While the device is discharging, the "Discharging" icon lights up.
4		If a fault occurs during the operation of the device, an "Error xx" prompt will pop up, and the fault can be rectified according to the fault list.
5		Low battery warning.



The display screen will be black after 10 minutes of inactivity. At this time, press the "LAMP" button on the right side of the cabinet to wake up the display screen again.

The error codes on the display screen are explained in the table below.

Error code	Error name	Solution
Error 01	Battery overvoltage protection	<ul style="list-style-type: none"> ● Press the one-key battery power-on button on the power distribution box, wait for the battery to shut down completely, and then press the one-key battery power-on button again to restart the battery. ● Set the inverter mode to discharge the battery to SOC 80%~90%.
Error 02	Battery undervoltage protection	<ul style="list-style-type: none"> ● Press the one-key power-on button on the power distribution box, wait for the battery to shut down completely, and then press the one-key power-on button again to restart the battery. ● Set the inverter's mode to charge the battery.
Error 03	Battery over temperature protection	<ul style="list-style-type: none"> ● Check whether the ambient temperature of the product is too high. ● Press the one-key power-on button on the power distribution box, wait for the battery to shut down completely, and then press the one-key power-on button again to restart the battery.

Error 04	Battery low temperature protection	<ul style="list-style-type: none"> ● Check whether the ambient temperature of the product is too low. ● Press the one-key power-on button on the power distribution box, wait for the battery to shut down completely, and then press the one-key power-on button again to restart the battery.
Error 05	Battery discharge overcurrent protection	<ul style="list-style-type: none"> ● Check whether the load power exceeds the product specification. ● Press the one-key power-on button on the power distribution box, wait for the battery to shut down completely, and then press the one-key power-on button again to restart the battery.
Error 06	Battery charging overcurrent protection	<ul style="list-style-type: none"> ● Press the one-key power-on button on the power distribution box, wait for the battery to shut down completely, and then press the one-key power-on button again to restart the battery. ● Set the inverter's mode to discharge the battery to fault recovery.
Error 15	Communication error	<ul style="list-style-type: none"> ● Check whether the communication cables of the display control board and the battery are connected. ● Check that the battery has matching resistors installed.

5 Maintenance and Common Fault Handling

5.1 routine maintenance

- The system is calculated from the factory and needs to be charged every 6 months.
- When the device is not used for a long time, it is necessary to discharge the battery to between 45% and 60% of the power, and disconnect the battery output to prevent the battery from emptying.
- During the storage period of the system, professionals should regularly check the system to check whether the lines are loose or fall off, or clean the surface and interior of the system; if any defects are found, please contact the dealer in time.
- Check the inverter every 6 months or 1 year to verify if there are damages on cables, accessories, terminals and the inverter itself.
- Check the inverter every 6 months to verify if the operating parameter is normal and there is no abnormal heating or noise from the inverter.
- Check the inverter every 6 months to confirm there is nothing that covers the inverter heat sink, if there is, shut-down the inverter and clear the heat sink.

5.2 Battery fault handling

Error phenomenon	Reason	Solution
POWER button does not respond	One-button start cable is damaged or has poor contact	Open the side door and close the POWER button on any battery to turn on all battery packs with one button.
		Please contact the supplier.
Short discharge time	Low battery	Keep the product charged continuously for more than 4 hours to fully charge the energy storage battery system.
	Product overload	Check load status and remove non-essential loads.
	Batteries age and capacity decreases	To replace the battery, please contact the supplier for the battery and its components
Unable to charge and discharge	Internal failure	Please contact the supplier
	Battery report charging or discharging protection failure	Find out the corresponding fault cause according to the battery indicator function status table;
	After the battery is discharged to the SOC protection value, it needs to	The battery is charged to the SOC value set by the restart (the default setting value is 50%)

	be charged for a period of time before it is allowed to discharge.	
	Battery over temperature	Stand at room temperature for more than 3 hours
Battery communication abnormal	Communication disconnection	Check whether the battery CAN communication connection is tight.
A red light error message appears	Other	According to the fault information prompted, check the indicator light function status table to find out the corresponding fault cause;
The inverter is powered on for the first time through the battery, and the battery reports short-circuit protection	The parallel capacitor value of the input terminal on the battery side of the inverter is large	Battery protection can be automatically restored
Inverter won't start	The battery voltage is too low or the SOC is lower than the shutdown protection value	Charge the battery after starting the inverter from the grid
The battery cannot be charged through the grid	In the Battery Setting interface, there is no selection of "Grid Allowed Charging" or "Grid Allowed Charging" is not selected in the Time of Use setting interface.	1.Check whether the Grid Charge of Battery Setting in the LCD screen is enabled. 2.Check whether the Grid Charge of Time of Use in System Work Mode on the LCD screen is enabled
	Battery failure protection	According to the fault information prompted, check the indicator light function status table to find out the corresponding fault cause;
	Grid Abnormal	Check whether the grid voltage is normal.

5. 3 Inverter fault handling

5.3.1 Regular Maintenance



Inverter Maintenance

a.Check the inverter every 6 months or 1 year to verify if there are damages on cables, accessories, terminals and the inverter itself.

b.Check the inverter every 6 months to verify if the operating parameter is normal and there is no abnormal heating or noise from the inverter.

c. Check the inverter every 6 months to confirm there is nothing that covers the inverter heat sink, if there is, shut-down the inverter and clear the heat sink.

5.3.2 LED Displays

Green LED	Solid lit 	Working normally	
	Flashing 	Firmware upgrading	Wait till upgrading complete
Yellow LED	Solid lit	Warning, inverter working	Need troubleshooting
Red LED	Solid lit 	Fault, inverter stop work	Need troubleshooting

5.3.3 Troubleshooting Based On LCD Displays

Once there is any warning or fault occurring, users can troubleshoot according to the LED status and the warning/fault information on the LCD.

1. Fault on the LCD

If the dot on the left of fault item is red, it means the fault is active. When it is grey, it means the fault is deactive

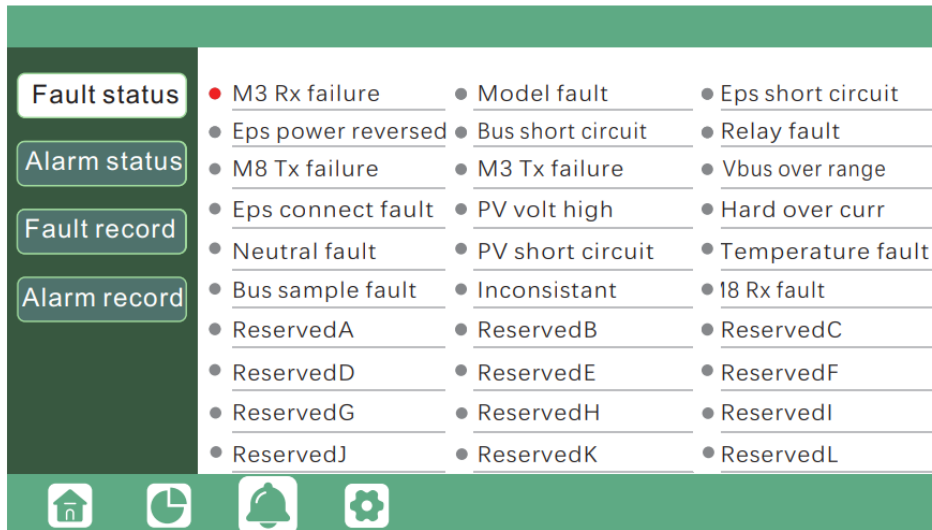

Fault	Meaning	Troubleshooting
M3 Rx failure	M3 microprocessor fails to receive data from DSP	Restart inverter, if the error still exists, contact your supplier.
Model fault	Incorrect model value	
Eps short circuit	Inverter detected short-circuit on EPS output terminals	1. Check if the L1, L2 and N wires are connected correctly at inverter EPS output port; 2. Disconnect the EPS breaker to see if fault remains. If fault persists, contact your supplier.
Eps power reversed	Inverter detected power flowing into EPS port	Restart inverter, if the error still exists, contact your supplier.
Bus short circuit	DC Bus is short circuited	
Relay fault	Relay abnormal	
M8 Tx failure	DSP fails to receive data from M8 microprocessor	
M3 Tx failure	DSP fails to receive data from M3 microprocessor	Please check if the PV string voltage is within the inverter specification. If string
Vbus over range	DC Bus voltage too high	

		voltage is within range, and this fault still appears, contact your supplier.
Eps connect fault	EPS port and grid port are connected mixed up	Check if the wires on EPS port and grid port are connected correctly. If the error exists, contact your supplier.
PV volt high	PV voltage is too high	Please check if the PV string voltage is within the inverter specification. If string voltage is within range, and this fault still appears, contact your supplier.
Hard over curr	Hardware level over current protection triggered	Restart inverter, if the error still exists, contact your supplier.
Neutral fault	Voltage between N and PE is greater than 30V	Check if the neutral wire is connected correctly.
PV short circuit	Short circuit detected on PV input	Disconnect all PV strings from the inverter. If the error persists, contact your supplier.
Temperature fault	Heat sink temperature too high	Install the inverter in a place with good ventilation and having no direct sunlight. If the installation site is okay, please check if the NTC connector inside the inverter is loose.
Bus sample fault	Inverter detected DC bus voltage lower than PV input voltage	Restart inverter, if the error still exists, contact your supplier.
Inconsistent	Sampled grid voltage values of DSP and M8 microprocessor are inconsistent	
M8 Rx fault	M8 microprocessor fails to receive data from DSP	

1. Alarm on the LCD

If the dot on the left of fault item is yellow, it means the fault is active. When it is grey, it means the fault is detective

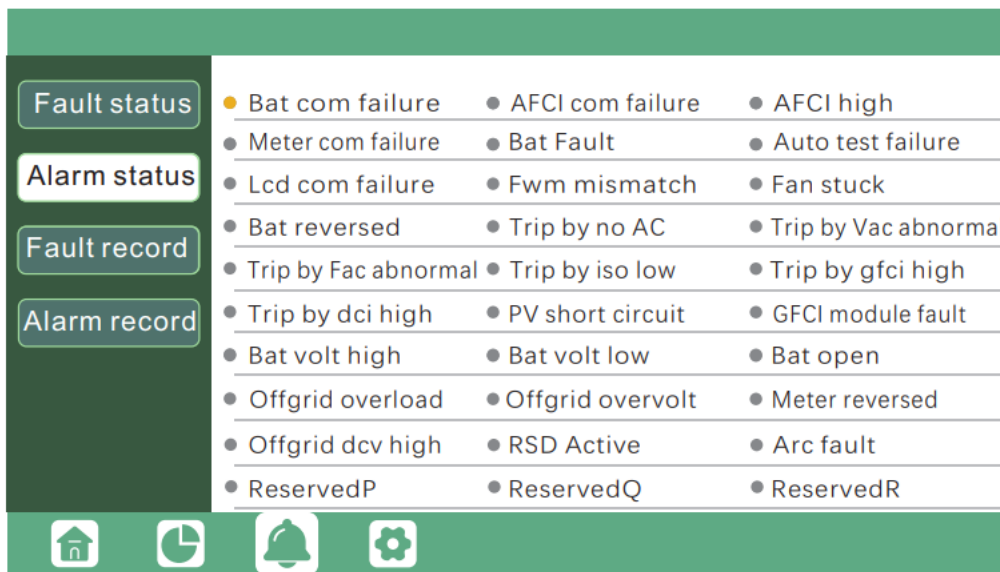

Alarm	Meaning	Troubleshooting
Bat com failure	Inverter fails to communicate with battery	Check if communication cable is correct, and if you have chosen the correct battery brand on inverter LCD. If all is correct but this error persists, please contact your supplier.
AFCl com failure	Inverter fails to communicate with AFCl module	Restart inverter, if the error persists, contact your supplier.
AFCl high	PV arc fault is detected	Check each PV string for correct open circuit voltage and short circuit current. If the PV strings are in good condition, please clear the fault on inverter LCD.
Meter com failure	Inverter fails to communicate with the meter	1. Check if the communication cable is connected correctly and in good condition. 2. Restart inverter. If the fault persists, contact your supplier.
Bat Fault	Battery cannot charge or discharge	1. Check the battery communication cable for correct pinout on both inverter and battery end; 2. Check if you have chosen an incorrect battery brand; 3. Check if there is fault on battery's indicator. If there is fault, please contact your battery supplier.
Auto test failure	Auto test failed	Only applied to Italy model
Lcd com failure	LCD fails to communicate with M3 microprocessor	Restart inverter. If fault still exists, contact your supplier.

Fwm mismatch	Firmware version mismatch between the microprocessors	
Fan stuck	Cooling fan(s) are stuck	
Trip by gfc high	Inverter detected leakage current on AC side	1. Check if there is ground fault on grid and load side;2.2. Restart inverter. If the fault remains, contact your supplier.
Trip by dci high	Inverter detected high DC injection current on grid port	Restart inverter. If the fault remains, contact your supplier.
PV short circuit	Inverter detected short circuited PV input	1.Check if each PV string is connected correctly; 2.Restart inverter. If the fault remains, contact your supplier.
GFCI module fault	GFCI module is abnormal	Restart inverter. If fault still exists, contact your supplier.
Bat volt high	Battery voltage too high	Check if battery voltage exceeds 59.9V, battery voltage should be within inverter specification.
Bat volt low	Battery voltage too low	Check if battery voltage is under 40V, battery voltage should be within inverter specification.
Bat open	Battery is disconnected from inverter	Check battery breaker or battery fuse.
Offgrid overload	Overload on EPS port	Check if load power on inverter EPS port is within inverter specification.
Offgrid overvolt	EPS voltage is too high	Restart inverter. If fault still exists, contact your supplier.
Meter reversed	Meter is connected reversely	Check if meter communication cable is connected correctly on inverter and meter side.
Offgrid dcv high	High DC voltage component on EPS output when running off-grid	Restart inverter. If fault still exists, contact your supplier.
RSD Active	Rapid shutdown activated	Check if the RSD switch is pressed.

5.3.4 Fan replacement

Please check and clean the fans regularly. The recommended period is 6 months.

Please replace the fan following up the below diagram if there is problem with the fans. Turn off the system and wait for more than 5 minutes before disassembling the machine.

- a.Open the wiring cover
- b.Unplug the fan cable

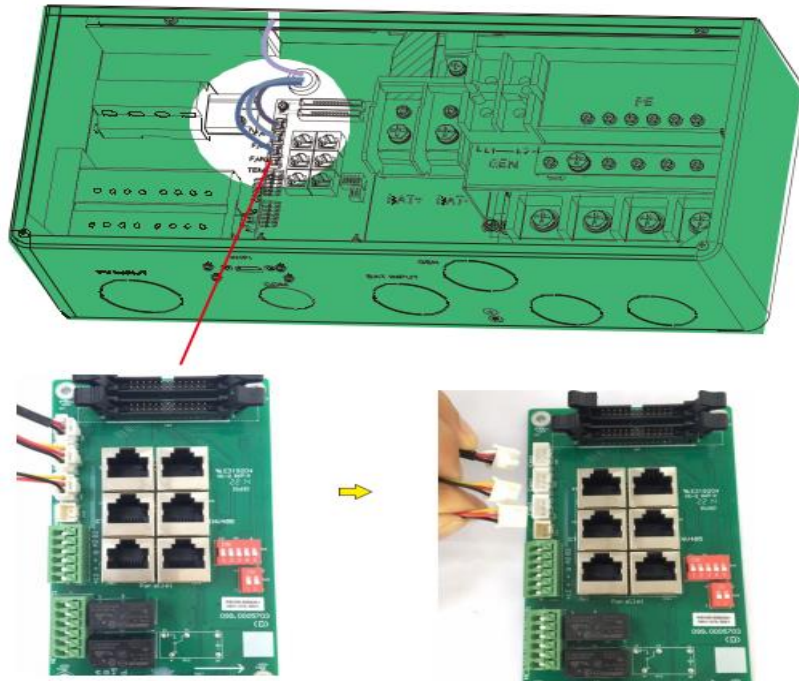

c. Loosen the screws and remove them

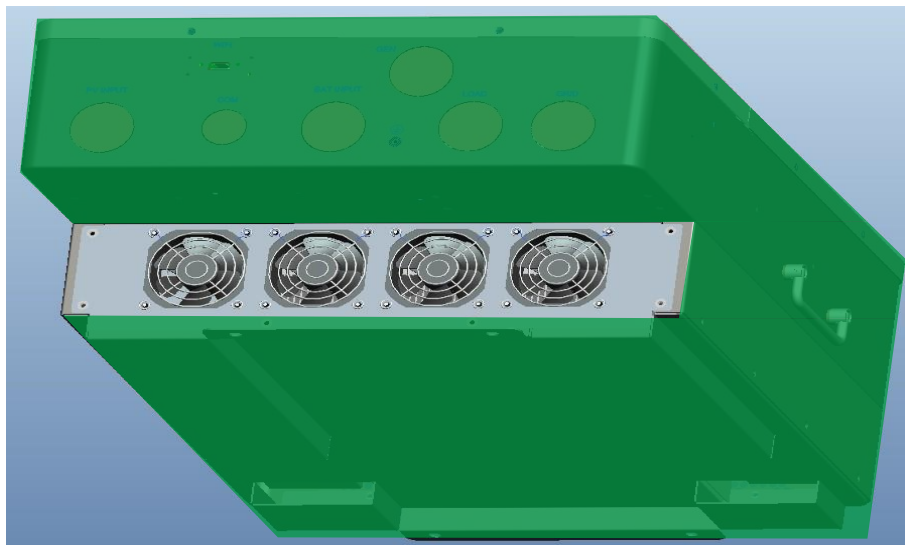

d. Remove the fan fixing

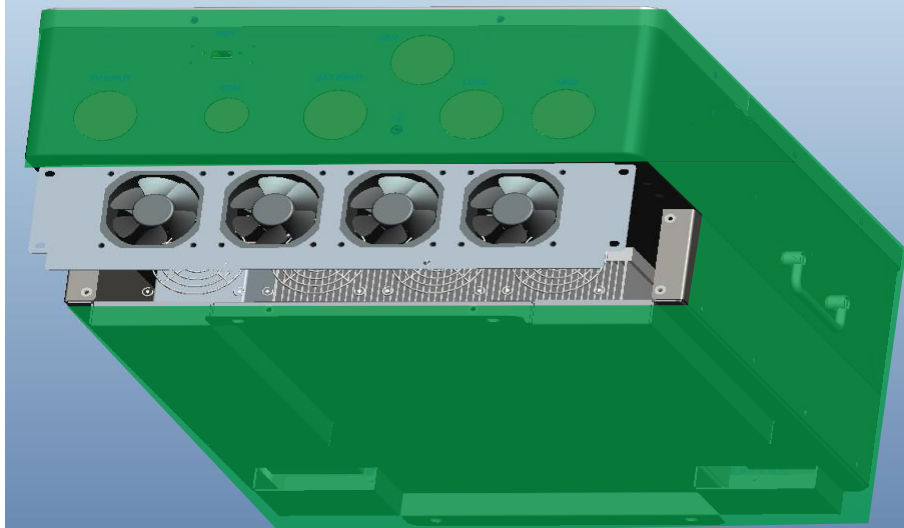

- e. Loosen the waterproof connector
- f. Remove the fan and replace it
- g. After the fan is installed, follow the steps just now to push back and assemble it back

6 Packaging, Shipping, Storage

- The system is packaged in a wooden box with an inner PE bag, which is moisture-proof and waterproof.
- EPE pearl cotton foam pad is used in the middle to prevent the system from being damaged during handling and transportation.
- Transportation must comply with UN3481 dangerous goods transportation and local laws and regulations.
- The system is heavy and must be handled mechanically.
- Transport temperature: $-10^{\circ}\text{C} \sim 40^{\circ}\text{C}$.
- The equipment and packaging cannot be exposed to water, so they cannot be transported in the open air.
- Storage temperature: $-20^{\circ}\text{C} \sim 25^{\circ}\text{C}$, 12month;
 $-20^{\circ}\text{C} \sim 45^{\circ}\text{C}$, 3month;
 $-20^{\circ}\text{C} \sim 60^{\circ}\text{C}$, 1month;
 (The SOC is kept in the range of 40% to 60% before storage)
- Storage humidity: 10%~80%RH.
- The storage room should be kept ventilated, clean and dry, and protected from dust and water vapor.
- The storage time should not exceed 6 months at most, and it is recommended to charge and discharge the system after the time is exceeded.
- The sunlight in the storage room cannot directly shine on the system.

Appendix A Technical Data Sheet

Item	Parameter			Note
System model	SB5110	SB7615	SB1220	Tentative
Number of batteries in parallel	2	3	4	
Rated Capacity	200Ah	300Ah	400Ah	
Rated energy	10kWh	15kWh	20kWh	
The maximum discharge current of the system	180A	200A	240A	25°C
Dimensions	720*1850*570mm			W*H*D(estimate)
Weight	310kg	350kg	390kg	Prototype confirmation
Rated voltage	51.2V			
Operating voltage range	46.4V~55.2V			
External communication	CAN/RS485/WiFi			
Basic protection function	Charge overvoltage, discharge undervoltage, overcurrent, overtemperature, short circuit protection, etc.			
Cycle life	5000 times (25°C, 0.5C/0.5C, 90%DOD, remaining 70%)			
Scalable	Parallel connection of multiple cabinets on the AC side			
Protection class	IP55			
Working temperature	Charge: [-10,50]°C; Discharge: [-20,50]°C			
Working environment humidity	10%~95%RH			
Working altitude	<2000m			Derating over 2000m
Certification	UN38.3、UL1973、FCC 15 part class B、UL9540、UL9540A			

SUN  BEAT